

**STARPOWER** 548

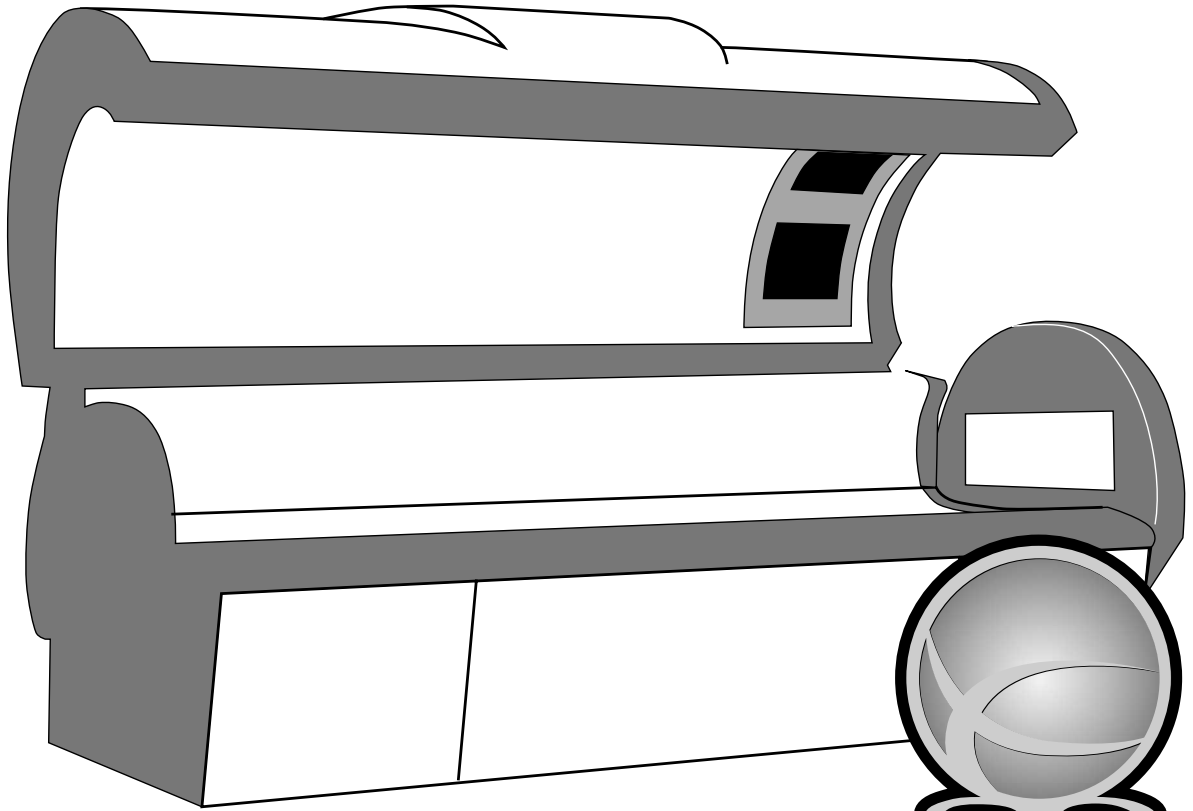

**USER  
Manual**



## **48 MONTH "GOLD MEDAL" WARRANTY**

Your ETS Distributor (including ETS, LLC if purchased directly), through a manufacturer's warranty, warrants your tanning unit to be free of structural defects in material and workmanship, under normal use, for its lifetime. Your ETS Distributor will, at its discretion, repair any structural defect which materially affects the performance of the tanning unit, or replace the tanning unit.

For forty-eight (48) months following the purchase date of your tanning unit, your ETS Distributor will provide replacements for parts that prove to be defective in material or workmanship, with the following exceptions: gas springs, ballasts and electronic lamp starters are warranted against manufacturer's defects for a period of one (1) year; "glow tube" lamp starters and cracked or broken endcaps are warranted against manufacturer's defects for a period of ninety (90) days; fluorescent lamps are warranted against manufacturer's defects for a period of thirty (30) days; acrylics are warranted against manufacturer's defects for a period of one (1) year (prorated) following the purchase date of your tanning unit. Shipping charges will be covered during the first ninety (90) days following the purchase date.

Your ETS Distributor (including ETS, LLC if purchased directly), also extends to you a two (2) year parts warranty on all T-Max® remote system components. External voltage transformers (buck-boosters) are covered by a one (1) year parts and labor warranty, provided you send back the defective transformer.

Labor costs associated with repair or replacement work covered by this warranty will be reimbursed for repair or replacement work required to be performed for a period of ninety (90) days following the shipping date of your tanning unit. Normal wear and tear, damage from misuse or abuse, damage incurred in transit or damages resulting from unauthorized repairs or modifications are not covered by this warranty. Warranty coverage does not include cosmetic abnormalities such as scratches, nicks, dents, or other cosmetic changes that do not materially interfere with the function of the tanning unit.

THIS 48 MONTH "GOLD MEDAL" WARRANTY IS EXPRESSLY MADE IN LIEU OF ANY OTHER WARRANTIES, EXPRESS OR IMPLIED, INCLUDING ANY IMPLIED WARRANTIES OF MERCHANTABILITY AND FITNESS FOR A PARTICULAR PURPOSE, WHICH ARE HEREBY DISCLAIMED. No one has the authority to change or modify this 48 Month "Gold Medal" Warranty in any respect. To obtain service under this 48 Month "Gold Medal" Warranty, contact your authorized ETS Distributor (or ETS, LLC if purchased directly). Proof of purchase, including serial number, is required.

IN NO EVENT SHALL YOUR DISTRIBUTOR OR THE MANUFACTURER BE LIABLE AT LAW OR IN EQUITY FOR ANY LOSS, LIABILITY, DAMAGE OR EXPENSE IN AN AMOUNT IN EXCESS OF THE PURCHASE PRICE RECEIVED, OR FOR LOSS OF USE OR PROFITS, LOSS OF TIME, INCONVENIENCE, RENTAL OR SUBSTITUTE PRODUCTS, LOSS OF BUSINESS, LOSS OF INCOME, OR ANY OTHER INCIDENTAL, INDIRECT, SPECIAL OR CONSEQUENTIAL DAMAGES. Some states do not allow the exclusion or limitation of incidental or consequential damages, and the above limitation or exclusion will not apply to residents of some states. This 48 Month "Gold Medal" Warranty gives you specific, legal rights and you may have other rights which may vary from state to state.

All warranty service must be performed by an authorized service person using only ETS authorized replacement parts. Use of non-authorized parts may void your warranty. All labor services must be authorized by your ETS Distributor prior to the start of repairs and must not exceed the established rates and time allotment policies established by your ETS Distributor. If your tanning unit must be returned for service within thirty (30) days from the purchase date, freight charges will be paid for by your ETS Distributor, after which all freight charges shall be at your expense. Contact your ETS Distributor for the authorized Service Center nearest you. This warranty is serial number specific and only applies to tanning units purchased through an authorized ETS Distributor. This warranty is extended to the individual or legal entity whose name appears on the original sales document and may not be transferred to any other individual or legal entity. This warranty is void if the tanning unit is modified in any manner from its original design.

**To obtain warranty service, contact your place of purchase. Proof of purchase, including serial number, is required for verification. Contact ETS, LLC only if you purchased your equipment directly.**

**ETS, LLC 7445 Company Drive, Indianapolis, IN 46237-9296  
1-800-449-3605 In Canada call 1-800-661-6292 or 519-421-1212**



# Welcome

---

Congratulations on your purchase of this technologically advanced sun tanning unit. It has been designed to provide years of dependable service for you.

Please read all the instructions in this booklet before installing and using the unit. Always be sure to observe all safety precautions.



# Contents

---

<b>Safety Information</b> .....	<b>.iii</b>
<b>Installation</b> .....	<b>1</b>
Unpacking and Inspection .....	1
Tools Required .....	1
Pre-Installation Planning .....	2
Hardware Inventory .....	2
Assembly Procedures .....	4
Electrical Connections .....	11
Final Adjustments .....	12
Remote Connections .....	13
<b>Operation</b> .....	<b>18</b>
Before You Tan .....	18
Exposure Times .....	18
Using Your Sunbed .....	19
<b>Care and Maintenance</b> .....	<b>21</b>
Cleaning After Use .....	21
Thorough Periodic Cleaning .....	21
Mechanical Inspection .....	21
Lamp and Acrylic Replacement .....	22
<b>Troubleshooting</b> .....	<b>26</b>



# Safety Information

**DANGER** Ultraviolet radiation. Follow instructions. Avoid overexposure. As with natural sunlight, overexposure can cause eye and skin injury and allergic reactions. Repeated exposure may cause premature aging of the skin and skin cancer. **WEAR PROTECTIVE EYEWEAR; FAILURE TO MAY RESULT IN SEVERE BURNS OR LONGTERM INJURY TO THE EYES.** Medications or cosmetics may increase your sensitivity to the ultraviolet radiation. Consult physician before using sunlamp if you are using medications or have a history of skin problems or believe yourself especially sensitive to sunlight. If you do not tan in the sun, you are unlikely to tan from the use of this product. Children, the elderly, or fair skinned people who always burn easily and either never tan or tan minimally should not use this equipment.

To use, lie down under canopy and pull down as far as adjustment will allow maintaining at least 3 inches (76 centimeters) between your body and canopy clear plastic panel and side tanner clear plastic panel, otherwise overexposure may occur. Minimum use distance elsewhere is touching the clear plastic panels. Do not use without clear plastic panels in place. Untanned persons should not tan on consecutive days during their first week of tanning. Never tan more than once a day. Tanning normally appears after the first few sessions and maximizes after approximately four weeks. Tan once or twice per week thereafter to maintain appearance. Persons already having a base tan may begin at advanced levels corresponding to the extent of their base tan.

RECOMMENDED EXPOSURE TIMES IN MINUTES		MAXIMUM EXPOSURE TIME IS 12 MINUTES				
Skin Type:		Level 1/Week 1 1st-3rd Sessions	Level 2	Level 3	Level 4	Subsequent Maximum
I Sensitive Skin	(Burns easily and severely and does not tan.)	NOT RECOMMENDED FOR TANNING				
II Light	(Burns easily and severely and tans minimally.)	2	4	7	10	12
III Normal	(Burns moderately and tans average.)	3	6	9	12	12
IV Dark	(Burns minimally, tans easily and above average.)	4	7	10	12	12

New lamps emit approximately 10% more ultraviolet radiation during the first 50 hours of operation. Recommended tanning times should therefore be reduced by approximately 10% during that period.

**WARNING:** • Read the instructions booklet before using this sunlamp product. • All persons in the room should wear protective eyewear when lamps are on. Recommended eyewear: provided eyeshields or equivalent eyewear as defined under 21 CFR 1040.20. Other types of eyewear may not provide adequate protection. Failure to use protective eyewear may result in severe burns or other eye injury. If discomfort develops, discontinue use and consult a physician.

ONLY THE FOLLOWING LAMPS HAVE BEEN CERTIFIED FOR USE IN THE 548:

**BRONZING SUN™ PLUS Wolff® Model BSP 71-T12-100WR BI-PIN** -or- **SPEED® 225R Wolff® Model SPD71-T12-225R Bi-Pin** (Bench lamps)  
**Velocity® VS-R™ Wolff® Model VEL71-T12-160W VS-R Bi-Pin** -or- **SPEED® 315VS-R Wolff® Model SPD75-T12-315VS-R VS-R Bi-Pin**  
 (Canopy and side tanner lamps)

**Heraeus E400 HPT** -or- **Philips Model HPA 400/30s** -or- **CosmoTech Model 23045** (SolarMax™ IFT facial unit)  
**COSMOLUX® RA plus 15504/40W** (Shoulder unit)

**DISCONNECT POWER BEFORE ATTEMPTING TO CLEAN, RELAMP, OR ENGAGE IN THE MAINTENANCE OF THIS PRODUCT.**

THIS EQUIPMENT MUST BE EARTH GROUNDED.

This product is in conformity with performance standards for sun lamp products under 21 CFR PART 1040.20 and ANSI/UL Standard 482. Certified to CAN/CSA Standard C22.2 NO. 224.





**DANGER** Rayonnement ultraviolet. Veuillez suivre les instructions. Évitez une exposition excessive. Tout comme pour les rayons du soleil, une exposition excessive peut causer des blessures aux yeux et à la peau et provoquer des réactions allergiques. Une exposition répétée peut causer le vieillissement prématuré de la peau et provoquer le cancer de la peau. **PORTEZ DES LUNETTES PROTECTRICES: LE NON-RESPECT DE CETTE CONSIGNE DE SÉCURITÉ PEUT ENTRAÎNER DE GRAVES BRÛLURES OU DES LÉSIONS OCULAIRES À LONG TERME.** Les médicaments ou les produits cosmétiques peuvent augmenter votre sensibilité au rayonnement ultraviolet. Consultez un médecin avant d'utiliser la lampe solaire si vous prenez des médicaments, si vous souffrez d'une maladie cutanée ou si vous croyez être particulièrement sensible aux rayons du soleil. Si vous ne bronzez pas au soleil, il est peu probable que vous bronzez sous une lampe solaire. Les enfants, les personnes âgées et les personnes qui ont une peau claire qui brûle facilement, ne bronze jamais ou alors très peu, ne devraient pas utiliser cette lampe.

Étendez-vous sous la partie supérieure, puis abaissez celle-ci aussi bas que possible, en veillant cependant à conserver un espace d'au moins 3 pouces (7,60 centimètres) entre le corps et le panneau de plastique transparent de la partie supérieure, afin d'éviter une exposition excessive. Les autres parties du corps peuvent toucher les panneaux de plastique transparents. N'utilisez pas la lampe sans les panneaux de plastique transparents. La première semaine de bronzage, les personnes qui n'ont pas un hâle initial ne doivent pas se faire bronzer tous les jours. Ne vous faites jamais bronzer plus d'une fois par jour. Le bronzage commence normalement à apparaître après les premières séances : il atteint son apogée au bout d'environ quatre semaines. Les personnes qui ont déjà un teint hâlé peuvent commencer à des niveaux plus élevés, selon l'importance de leur hâle initial.

**TEMPS D'EXPOSITION RECOMMANDÉ EN MINUTES LE TEMPS D'EXPOSITION MAXIMAL EST DE 12 MINUTES**

Type de peau:	Élevé 1/Semaine 1 1 <sup>ère</sup> -3 <sup>e</sup>	Élevé 2	Élevé 3	Élevé 4	Sem. suivantes Temps maximal
I <b>Peau sensible</b> (brûle facilement et ne bronze pas)	<b>NON RECOMMANDÉ</b>				
II <b>Peau claire</b> (brûle facilement et bronze très peu)	2	4	7	10	12
III <b>Peau normale</b> (brûle et bronze de façon modérée)	3	6	9	12	12
IV <b>Peau foncée</b> (brûle très peu, bronze plus facilement que la moyenne)	4	7	10	12	12

Les lampes neuves émettent approximativement 10 % de plus de rayons ultraviolets au cours des 50 premières heures de fonctionnement. Le temps de bronzage doit donc être réduit d'environ 10 % pendant cette période.

**AVERTISSEMENT :** • Lisez le livret d'instructions avant d'utiliser cette lampe solaire. • Les autres personnes présentes dans la pièce doivent aussi porter des lunettes protectrices lorsque les lampes sont allumées. Coquilles de protection pour les yeux recommandées: Les coquilles de protection fournies ou l'équivalent, tel que le stipule le document 21 CFR 1040.20. Les autres types de lunettes protectrices peuvent ne pas assurer une protection adéquate. Utilisé sans lunettes protectrices, ce produit peut causer des brûlures ou lésions oculaires graves. Si vous souffrez d'un malaise, arrêtez l'utilisation et consultez un médecin.

SEULES LES LAMPES SUIVANTES ONT ÉTÉ HOMOLOGUÉES POUR CET ÉQUIPEMENT :

**BRONZING SUN™ PLUS Wolff® Modèle BSP 71-T12-100WR BI-PIN -OU- SPEED® 225R Wolff® Modèle SPD71-T12-225R Bi-Pin** (banc seulement)  
**Velocity® VS-R™ Wolff® Modèle VEL71-T12-160W VS-R Bi-Pin -OU- SPEED® 315VS-R Wolff® Modèle SPD75-T12-315VS-R VS-R Bi-Pin**  
 (partie supérieure et appareil de bronzage à lampes latérales)

**Heraeus E400 HPT -OU- Philips Modèle HPA 400/30s -OU- CosmoTech Modèle 23045** (unité faciale)

**COSMOLUX® RA plus 15504/40W** (unité en bandoulière)

**Débrancher l'alimentation électrique avant de nettoyer l'appareil , d'en faire l'entretien ou de changer les lampes.**

Cet équipement doit être mis à la terre.

Ce produit est conforme aux normes de rendement pour les lampes solaires dans les documents 21 CFR, partie 1040.20 , ANSI/UL 482 , CAN/CSA C22.2 N° 224.



# Installation

## Unpacking and Inspection

The bench and canopy are each wrapped in plastic. Remove the plastic and, with a helper or two, grasp the canopy and pull it from the carton bottom. Do the same for the bench. **Do not attempt to lift either unit with the plastic still on as it may slip. The endcaps on the canopy should not be used to lift the unit.** The ballast tray is secured to the carton bottom with brackets. Remove these brackets from the ballast tray with a Phillips screwdriver.

Note! The cartons are reusable. You may wish to save them for future use.

After unpacking the unit, check to make sure you have received the following:

- Canopy unit
- Bench unit
- Rear lamp module
- Ballast tray
- Access panel
- Two large bench endcaps
- Body fan kit
- Shoulder tanner kit
- Two bags containing necessary assembly hardware, safety goggles, a pillow and a tube of touch-up paint.

Inspect these items, including the canopy and bench, to make sure they are free from any visible damage. Report the extent of any damage to the transportation company.

Record the serial number of the unit in the area provided at the back of this manual. This information will be required whenever you call customer service.

## Tools Required

You will need the following tools to assemble your sunbed.

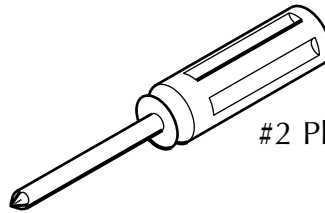

#2 Phillips Screwdriver

-AND-

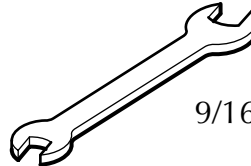

9/16" and 7/16" Wrenches

-OR-



Adjustable Wrench



## Pre-Installation Planning

Before you begin to assemble your sunbed, you should observe the following considerations.

	<b>⚠ WARNING</b>
	<b>Shock hazard. Disconnect power before servicing.</b>

<b>⚠ CAUTION</b>
<b>Use of a voltage source above 230V AC may prevent proper operation of the sunbed and could cause damage and void the warranty.</b>

<b>⚠ CAUTION</b>
<b>Air from the room is used to cool the sunbed. Maximum ambient room temperature should be 80°F. Place your sunbed no closer than 6" from any wall. Make sure nothing obstructs the airflow into or out of the fan openings. A poorly ventilated room may cause the unit to become hot and cause discomfort to the user.</b>

<b>⚠ CAUTION</b>
<b>Proper assembly of your sunbed requires four people. Plan to have a few helpers assist you.</b>

- The **STARPOWER® 548** operates from a 220V AC power source. The unit should be wired to a dedicated circuit capable of providing **60 Amp** service. This unit must be hardwired directly to a junction box. We recommend connection by a professional electrician.
- **IMPORTANT!** Voltage must be below 230V AC or may require a Buck Booster.

## Hardware Inventory

Open the hardware bags and remove the hardware. In addition to a pillow, an RJ-11 (phone type) cable and touch-up paint, make sure you have the following hardware items.

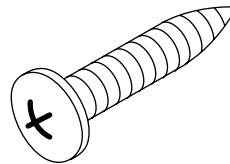

**#10 x 1" Phillips Pan Head Screw**  
Quantity 14

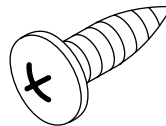

**#10 x 1/2" Phillips Pan Head Screw**  
Quantity 12

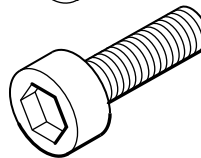

**3/8-16 x 1 1/4" Hex Socket Bolt**  
Quantity 18



**3/8-16 Self-locking Hex Nut**  
Quantity 18



# Installation - Hardware Inventory

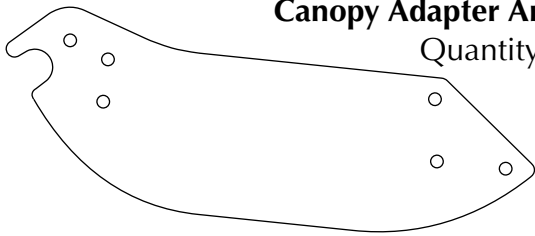

**Canopy Adapter Arm**  
Quantity 2

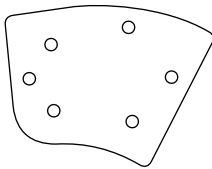

**Adapter Gusset**  
Quantity 4

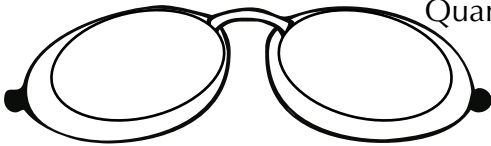

**Safety Goggles**  
Quantity 1

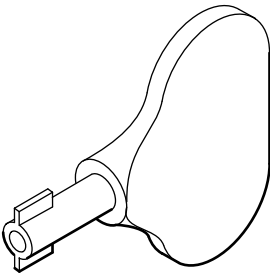

**Access Panel Key**  
Quantity 1

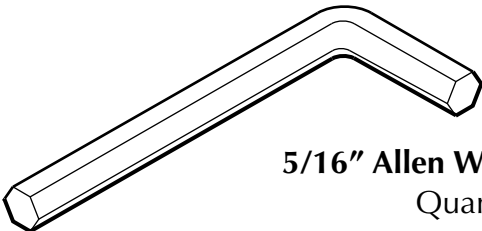

**5/16" Allen Wrench**  
Quantity 1

## *Additional hardware in Body Fan box*

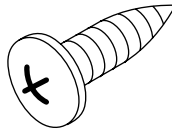

**#10 x 1/2" Phillips  
Pan Head Screw**  
Quantity 5

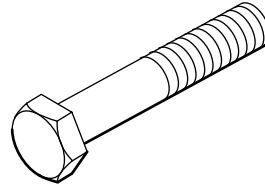

**1/4-20 x 1 1/2"  
Hex Head Bolt**  
Quantity 4

## *Hardware in Shoulder Tanner box*

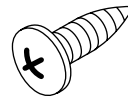

**#10 x 1/2" Phillips  
Pan Head Screw**  
Quantity 4



**5/16" Washer**  
Quantity 4

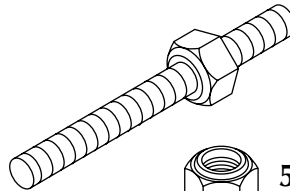

**5/16-18 Stud**  
Quantity 4



**5/16-18 Self-locking  
Hex Nut**  
Quantity 4

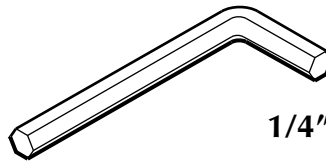

**1/4" Allen Wrench**  
Quantity 1



## Assembly Procedures

Before installing the bench endcaps you must install the body fan power cord into the foot end endcap, as shown below, and the shoulder tanning unit power cord into the head end endcap. The connector will snap securely into the endcap.

Snap body fan power cord into hole in foot end endcap.

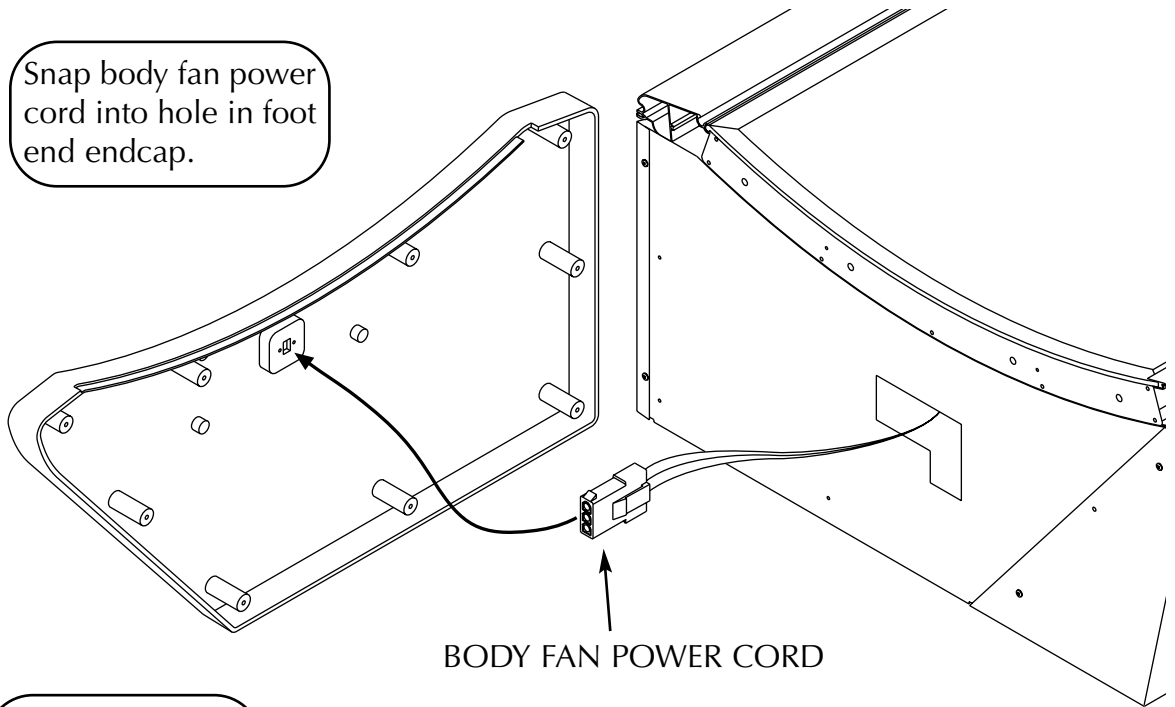

Foot end endcap shown.



## Installation - Assembly Procedures

Parts needed:

Foot end endcap

Head end endcap

14 - #10 x 1" Phillips pan-head screws

4 - #10 x 1/2" Phillips pan-head screws

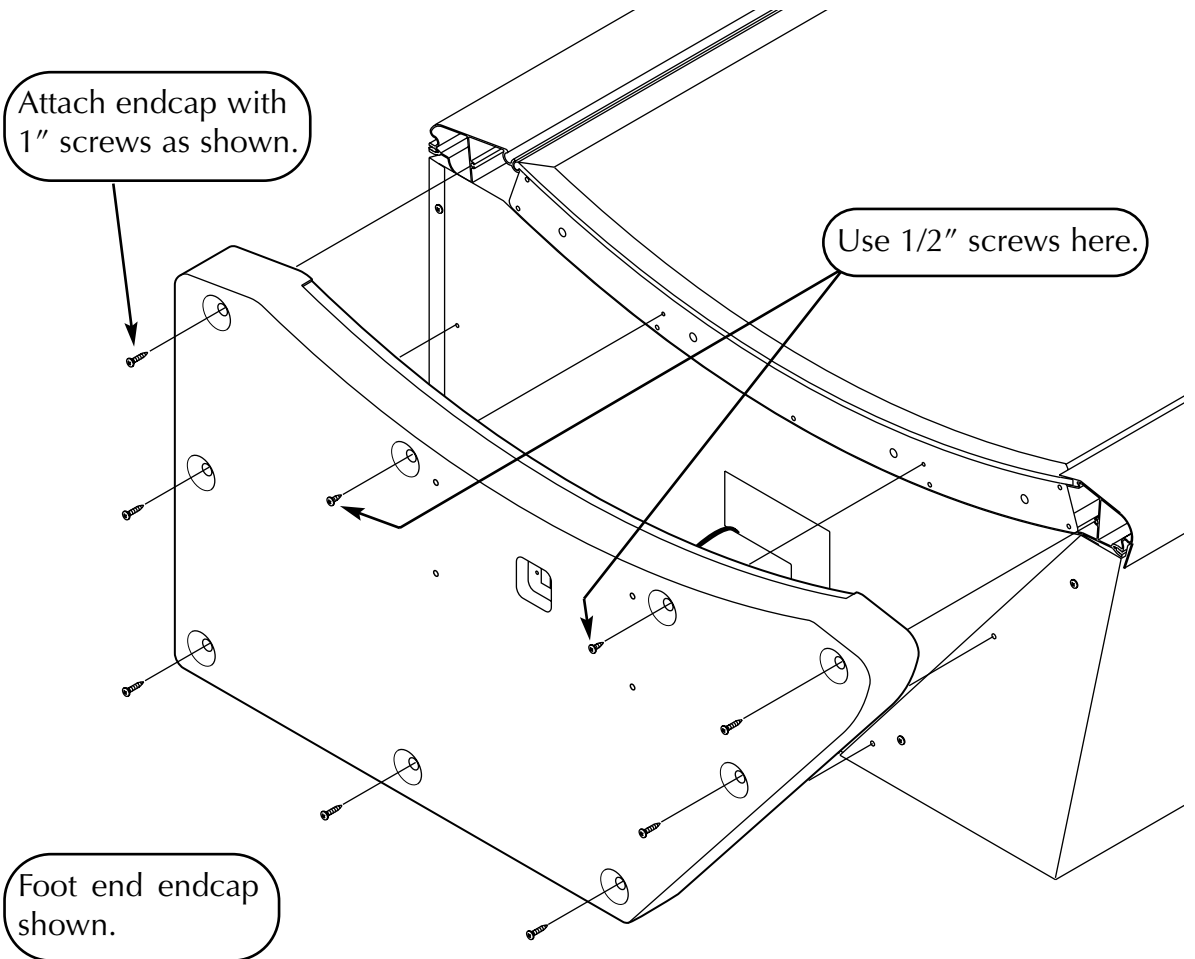



Parts needed:

Canopy

2 - Canopy Adapter Arms

4 - Adapter Gussets

12 - 3/8 x 1 1/4" hex-socket bolts

12 - 3/8" self-locking hex nuts

Attach adapter arms to canopy arms using two adapter gussets and six bolts and nuts.

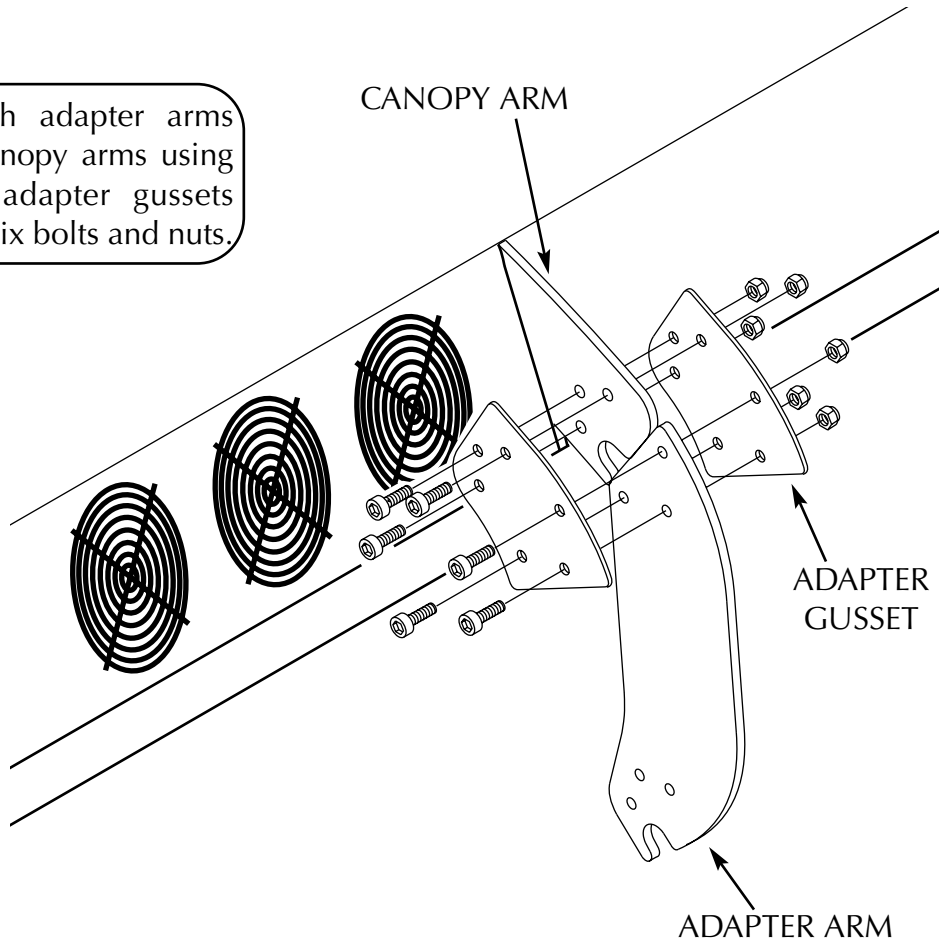



## Installation - Assembly Procedures

Parts needed:

6 - 3/8 x 1 1/4" hex-socket bolts

6 - 3/8" self-locking hex nuts

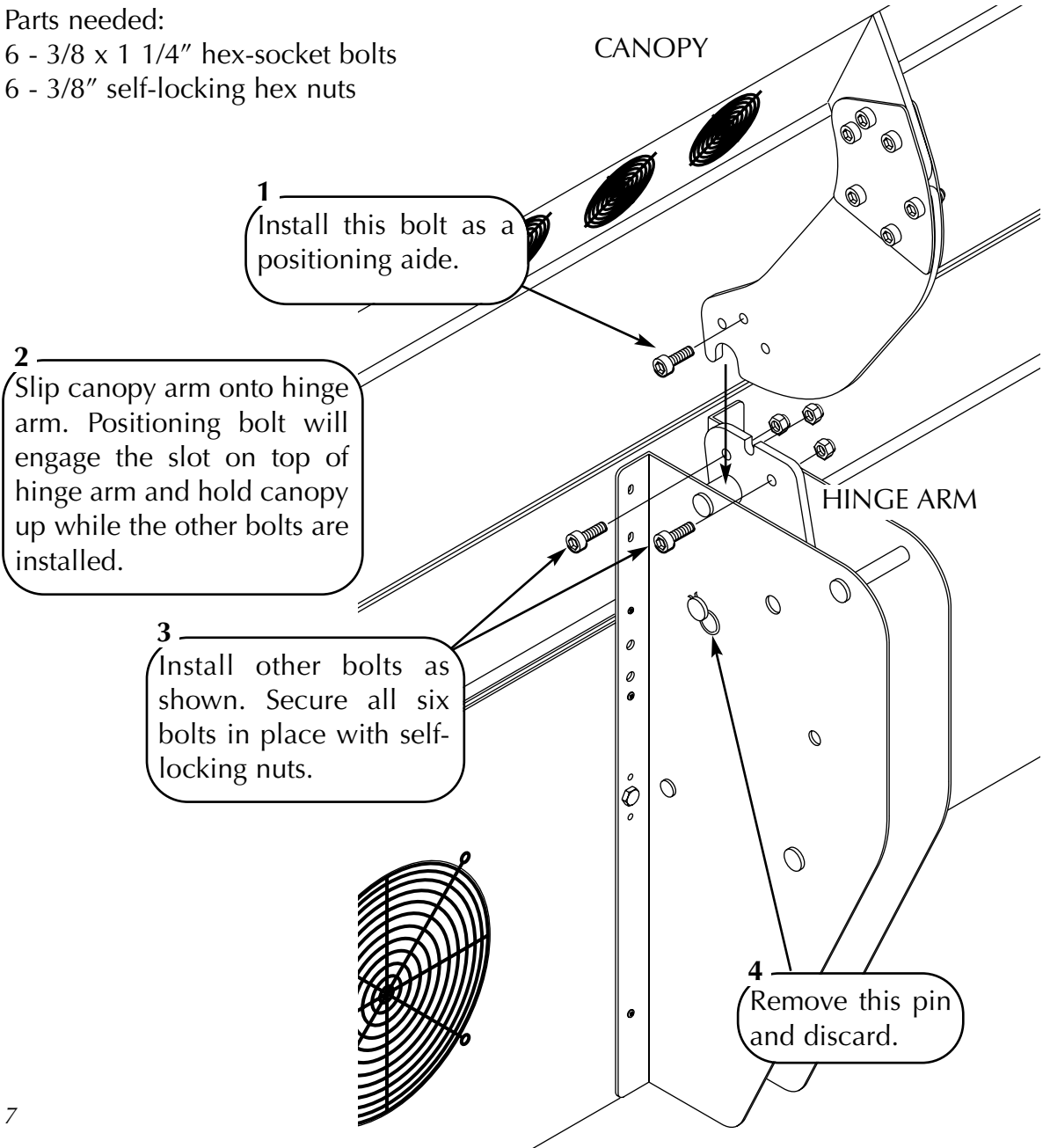



Parts needed:  
Rear lamp module  
8 - #10 x 1/2" Phillips pan-head screws

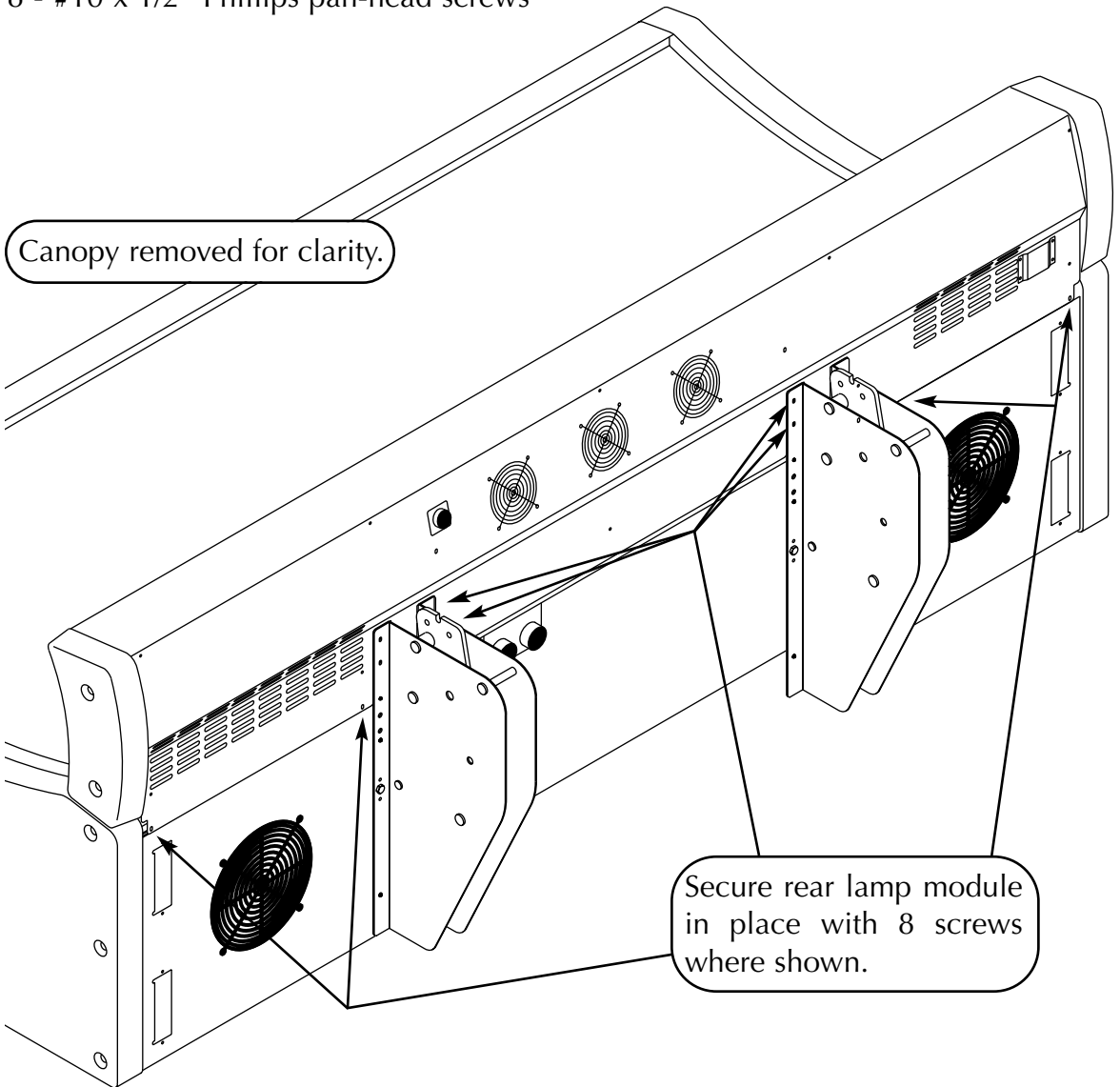



## Installation - Assembly Procedures

---

Parts needed:  
Body fan kit  
Shoulder tanner kit

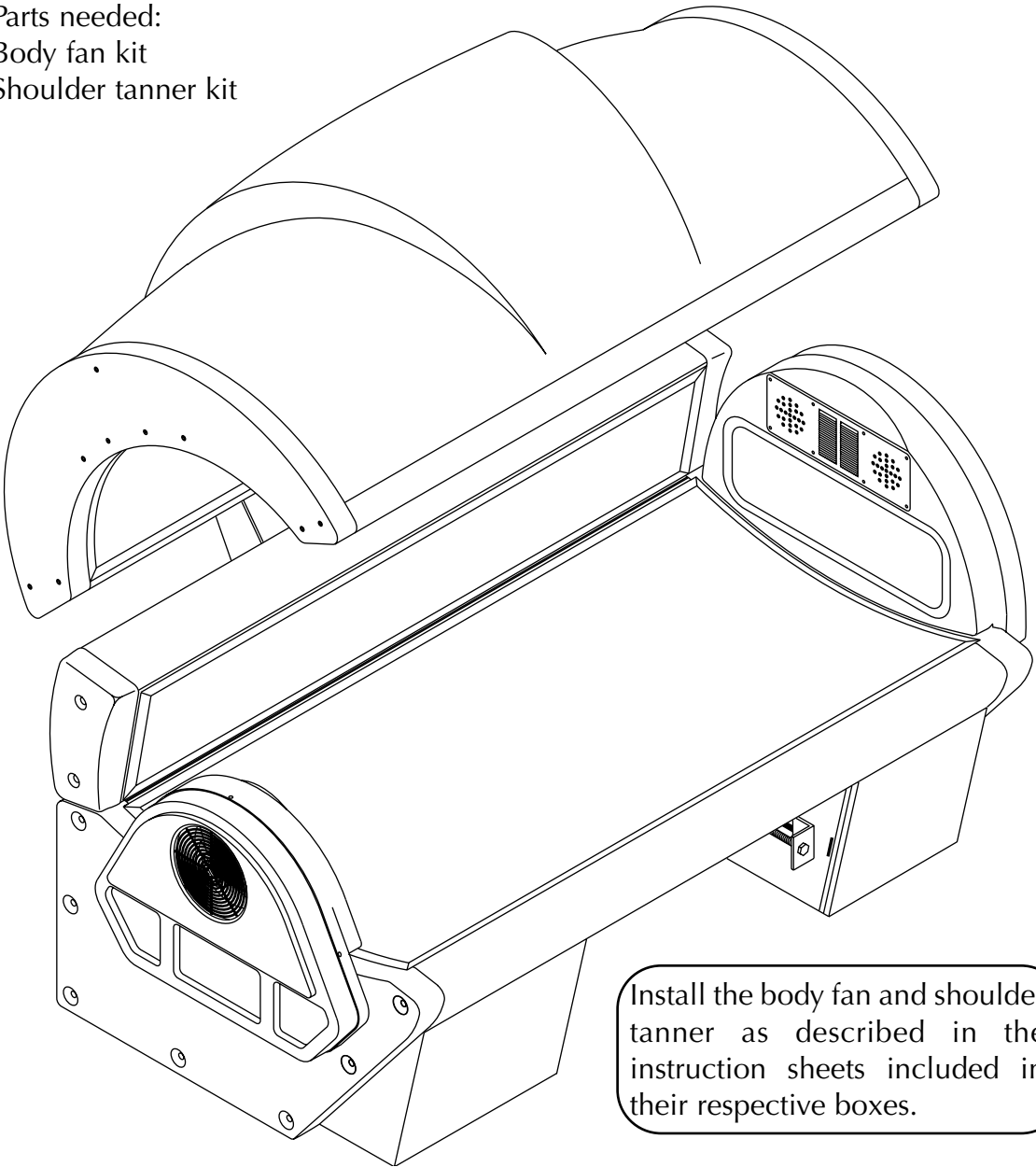

Install the body fan and shoulder tanner as described in the instruction sheets included in their respective boxes.



Slide the ballast tray under the unit and pull the cords through to the rear. Install the access panel by putting it in place and locking with the access panel key.

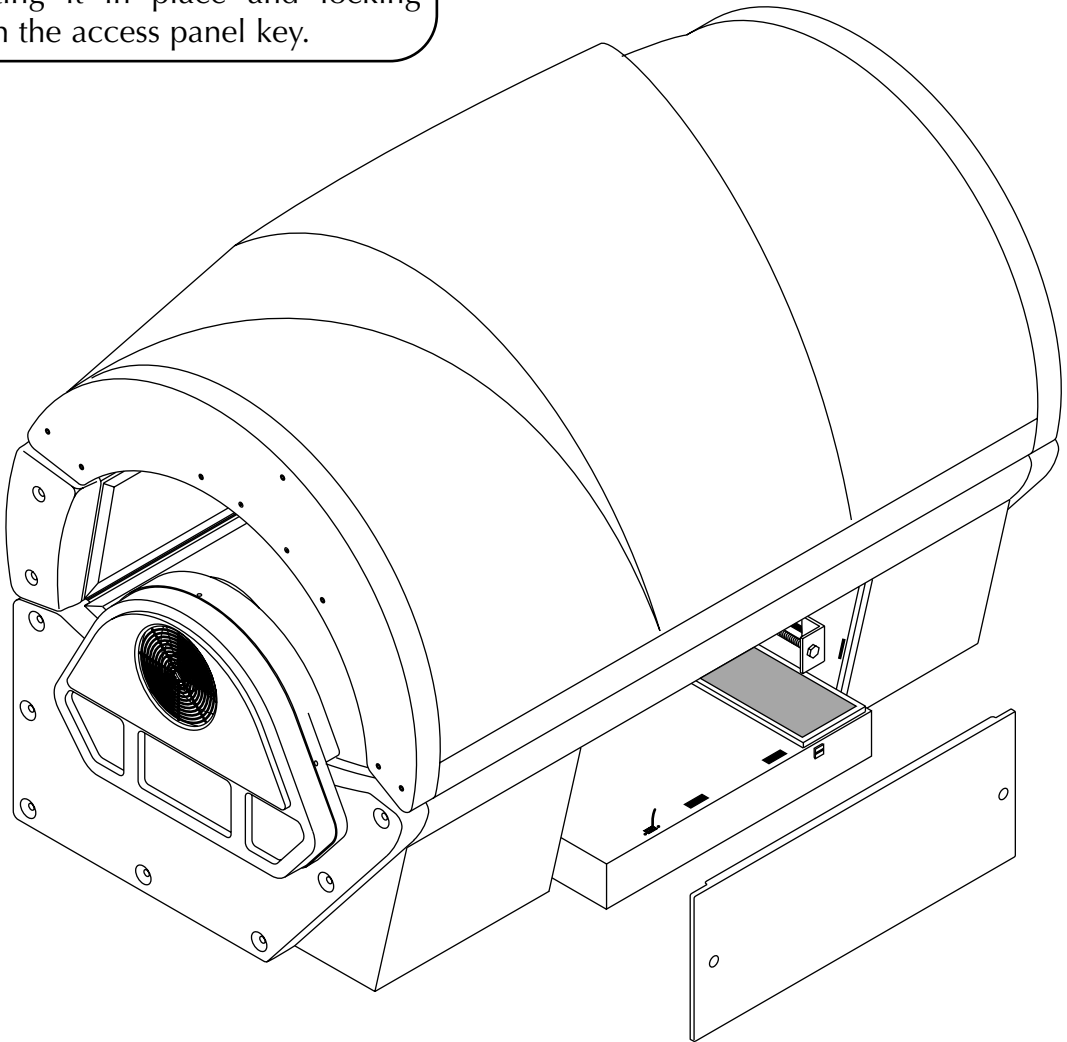



## Electrical Connections

At the rear of the sunbed, connect the two canopy power cords, two bench power cords and rear lamp module cord from the ballast tray to their respective power receptacles. Simply match the plug to the receptacle, push on firmly and secure by twisting the threaded locking ring.

**Helpful Hint:** Line up the plug with the proper receptacle and push in. Apply pressure to the plug and twist the locking ring counter-clockwise until you feel the plug click into place. Then turn the locking ring clockwise to secure it. The ring will click when fully engaged.

Connect the RJ-11 (phone type) cable between the canopy and rear jack on the ballast tray. The three jacks on the front of the tray are for remote connections. Connect main power cord as described in *Pre-Installation Planning*.

PIN CONFIGURATIONS MAY VARY FROM SHOWN

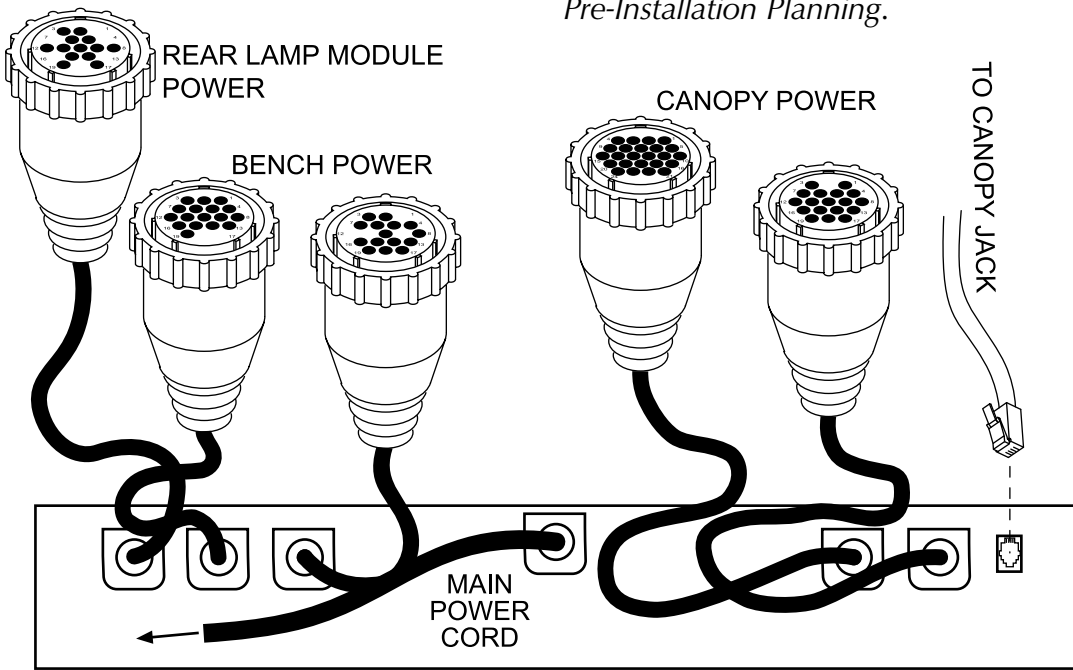

(Rear of ballast tray shown)



## Final Adjustments

Your sunbed uses a smooth gliding spring lift system to raise the canopy. This lift system may need to be adjusted slightly due to shipment. Remove the front access panel. Use a wrench to turn the hex shaped Lift Adjustment lugs (shown below), clockwise for more lift and counterclockwise for less. When adjusted properly, the canopy should raise easily as well as rest fully closed. Always adjust both lugs equally.

Make sure the air filters are in place. The filter on top of the ballast tray simply sits over the vent holes. Airflow holds it in place when the unit is on. The airflow arrow on the side of this filter should point down. The filter hanging under the bench should be installed with the arrow pointing up.

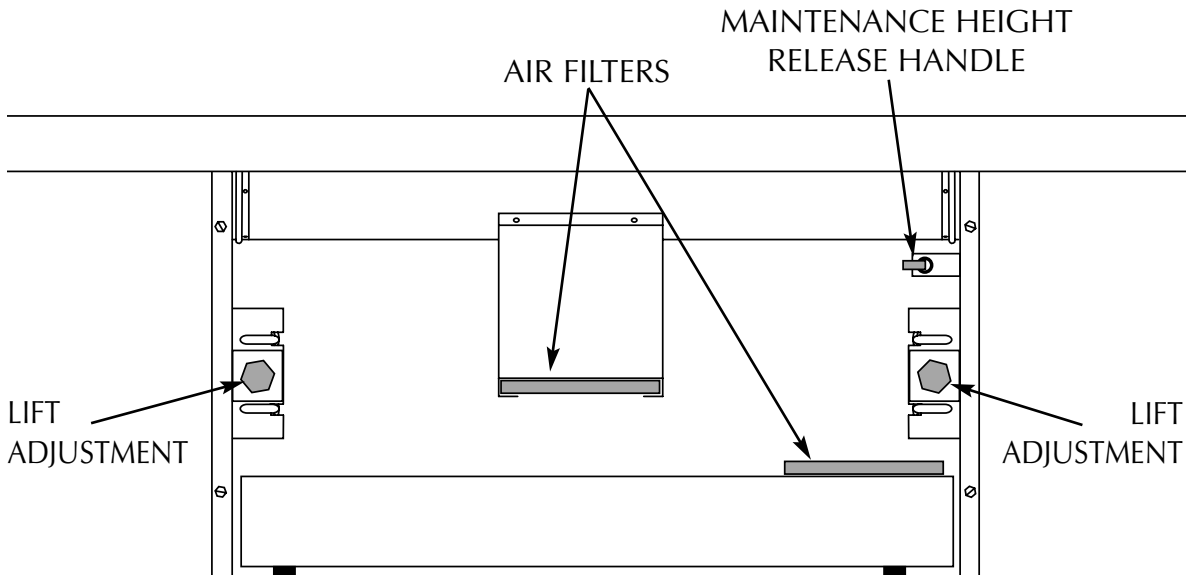



## Remote Connections

Your sunbed incorporates advanced circuitry allowing it to connect and communicate with most remote control systems. If a remote system is to be used, first determine whether the remote system is a T-Max® System or a standard remote system operating with a control relay. The following pages outline many different remote connection scenarios. Find the scenario that best fits your application.

Three remote ports are located on top of the ballast drawer at the front, two RJ-22 (4-wire) ports and one RJ-11 (6-wire) port. A Remote Control Bypass plug is already installed in one of the RJ-22 remote control ports. Your sunbed will not operate without the Remote Control Bypass plug or a remote system connected.

**ATTENTION:** Although the Remote Control Bypass plug provided with your sunbed will work wherever a T-Max® terminator is called for in the series, the T-Max® terminator will not work as a bypass plug. Normally, a bypass plug is needed only when your sunbed is operated without a remote system connected.

You will notice some wire clamps along the side of the fan housing under the bench. These are for the remote cables to keep them out from under the ballast drawer when rolling the drawer in and out of the unit. Route the remote cables as shown below, leaving some slack for the drawer to roll out.

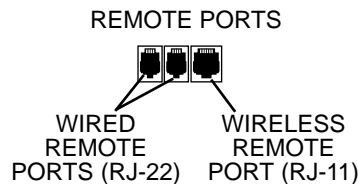
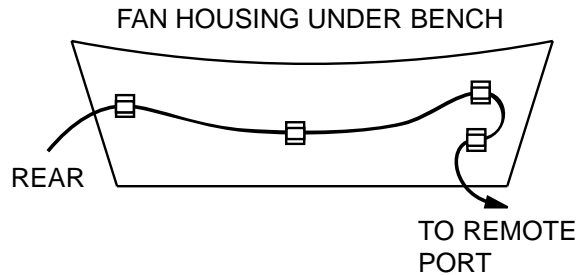



### **T-Max® Products**

The T-Max® remote systems offer the ultimate in sunbed control, while allowing the tanner easy straightforward operation. Your sunbed is configured to directly connect to this system, including the new wireless remote system. The circuitry inside your sunbed eliminates the need for the T-Max® 1A or 3A when connecting to the T-Max® Manager series. Your sunbed supports the auto addressing feature of the latest T-Max® Manager models and the following parameters: 5, 6, 7, 8, 9, 10, 15 and 23. See your T-Max® manual for descriptions of these parameters and how they function.

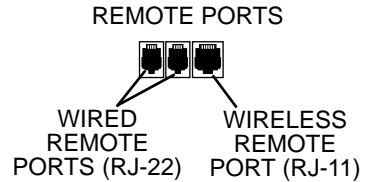

### **T-Max® Wireless Remote System**

The T-Max® AP-900 eliminates wires in your salon, allowing easy setup without hiring an electrician to run wires. It also protects your investment from damage by isolating each unit from one another. Your sunbed arrives “wireless ready”, which means it connects directly to the T-Max® wireless system. Older tanning beds, and T-Max® managers, also utilize this system but require a T-Max “Power Injector” (PI) to provide the needed power to the wireless unit.

### **CAUTION**

The remote connection is not designed to supply or accept high voltage, nor can it provide power to an external timer. The sunbed’s remote interface circuitry operates on 5 volts, attempting to connect it to any higher voltages will damage the sunbed as well as void your warranty.

### **Remote System Hook-up Scenarios**

Follow the diagrams on the next few pages to see the many different scenarios for hooking up your salon. If you need further assistance, call T-Max® directly at (417) 338-5101.



# Installation - Remote Connections

## Scenario 1 - T-Max® Manager Series with Complete Wireless

Connect one AP-900 (with Power Injector) to the Manager and one AP-900 to each of the tanning beds. Install as many beds as you like with this configuration. Units that do not communicate with T-Max will need an AP-900 with Power Injector and an additional 3A to operate. If you have an older T-Max® Manager that doesn't support auto addressing, set the address of each sunbed manually as described in *Setting the address manually*. You can place your sunbed at any location in the series.

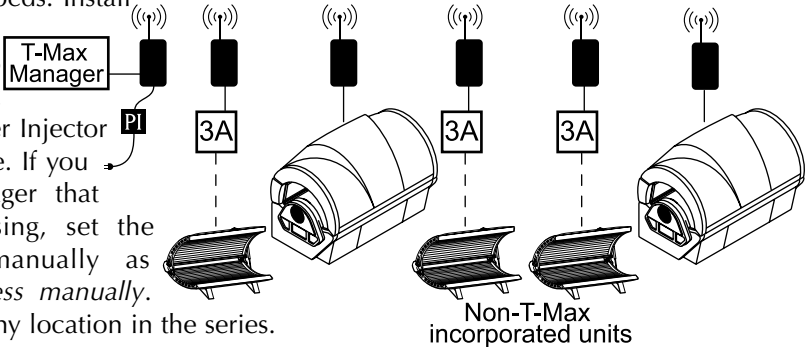

## Scenario 2 - T-Max 3A with Wireless

In single sunbed installations, the T-Max® 1A and 3A can offer the same control as the T-Max® Manager, eliminating the need for a Manager. If you're using a 1A in this manner, it must have a chip labelled "master" installed on its circuit board. The remote control bypass plug must not be used in this configuration. The 3A may be used as a "master" with no modification.

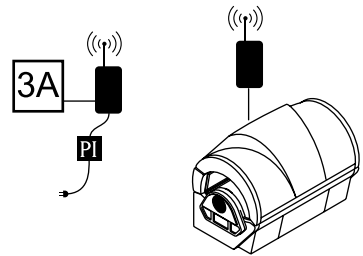

After you have set the T-Max® 1A's, or 3A's, address to "0" (refer to your T-Max® user's guide) and the sunbed's address to "1", simply connect one AP-900 (with Power Injector) to the T-Max® 3A and one AP-900 to the tanning bed.

NOTE: A T-Max® 1A with a "master" chip can be substituted for a 3A.

## Scenario 3 - T-Max® Manager Series with Wireless combo

Connect one AP-900 (with Power Injector) to the Manager and one AP-900 to a wireless ready tanning bed. The rest of the salon may be "daisy-chained" together and connected to the wireless equipped tanning bed, eliminating the need to wire the Manager to the tanning beds.

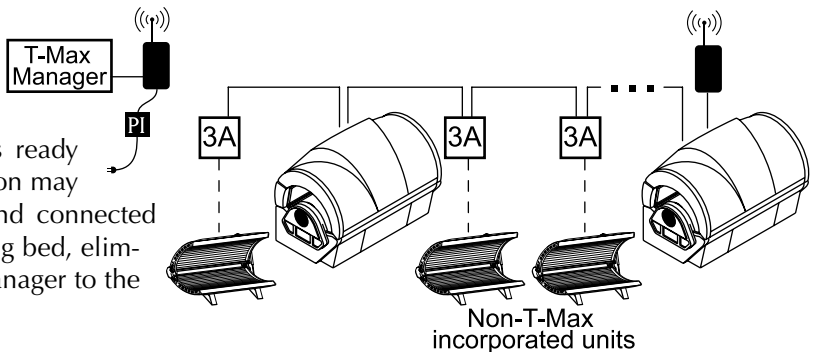



**Scenario 4 - T-Max® Manager Series with Wireless combo 2**

Wireless can be easily added to an existing salon already utilizing T-Max®. Connect one AP-900 (with Power Injector) to the Manager and one AP-900 to each wireless ready tanning bed. The rest of the salon may be “daisy-chained” together and connected to the Manager.

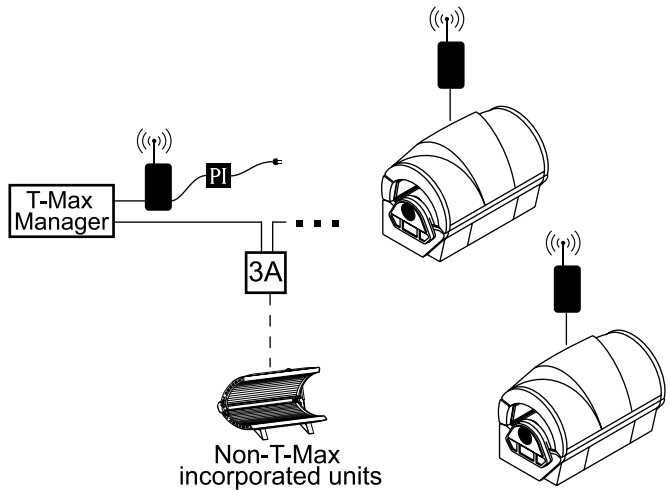

**Scenario 5 - T-Max® Manager Series with wires**

As always, this tanning bed is fully compatible with a wired T-Max® system. Simply connect the RJ-22 modular cable(s), described in the T-Max® Manager manual, into either of the smaller remote port(s) located on the ballast drawer and follow the instructions that came with your remote system.

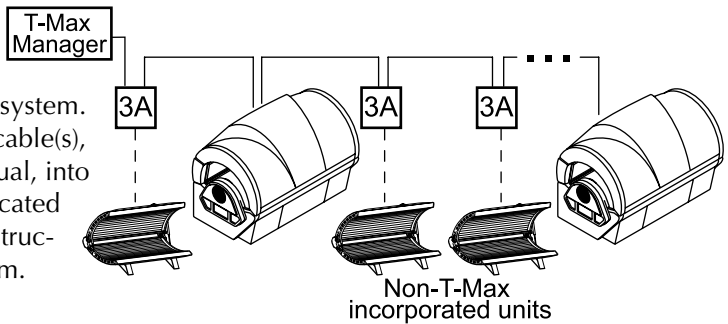

**Scenario 6 - Single Bed wired to T-Max® 3A**

In single sunbed installations, the T-Max® 1A and 3A can offer the same control as the T-Max® Manager, eliminating the need for a Manager. If you're using a 1A in this manner, it must have a chip labelled “master” installed on its circuit board. The remote control bypass plug must not be used in this configuration. The 3A may be used as a “master” with no modification.

After you have set the T-Max® 1A's, or 3A's, address to “0” (refer to your T-Max® user's guide) and the sunbed's address to “1”, simply connect the RJ-22 modular cables, described in the T-Max® user's guide, directly into either of the smaller ports located on the ballast drawer and either port on the back of the T-Max® 1A or 3A.

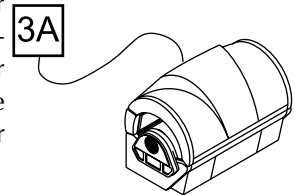



## Scenario 7 - Non T-Max® Remote System wired to unit

Most non-T-Max® remote systems control the sunbed by the use of a relay. The relay operates the sunbed by connecting and disconnecting a pair of wires leading from the sunbed. Refer to the user’s manual provided with your remote system to determine if it operates in this way. To connect your sunbed to this type of system a remote interface kit is required. Contact your place of purchase to obtain the kit. The illustration below details a typical connection. Follow the instructions provided with the kit and from the remote’s manual to make the necessary connections.

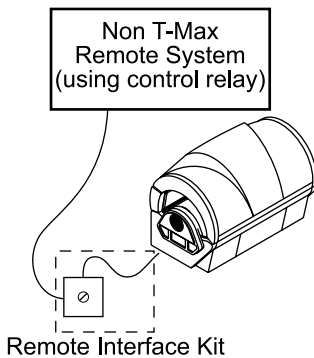

### CAUTION

The remote connection is not designed to supply or accept high voltage, nor can it provide power to an external timer. The sunbed’s remote interface circuitry operates on 5 volts, attempting to connect it to any higher voltages will damage the sunbed as well as void your warranty.

## Setting the sunbed address manually

Before connecting your sunbed to the T-Max® Manager or T-Max® 1A or 3A, the address of your sunbed must first be set. Set the “id” manually as described below.

### Setting the “id”

1. Make sure no cables are plugged into your sunbed’s remote ports.
2. Remove and reapply power to the unit.
3. Press and hold the stop button, located on the sunbed display, for three seconds and release. The display should indicate an “id” number from “oF” to “252”.

1-99

100-199

200-252

4. If you are using a T-Max® 1A or 3A as a “master” remote, the “id” of the sunbed must be set to “1”. If you are using a T-Max® Manager each sunbed must be assigned a different “id”. To set the “id” press the timer button, to count up, or the body fan control button, to count down, until the desired number is achieved.
5. Press the stop button to return to the normal display mode.



## Before You Tan

Before using your sunbed, please note the following important precautions.

- Your skin should be free of cosmetics, oils, or other body lotions prior to tanning except for those specifically made for use with tanning devices. However, do not remove natural body oils by bathing or showering immediately before tanning.
- Your hair should be free of gels, mousses, sprays, or other hair products prior to tanning. These products can cause damage to the sunbed acrylic. As an alternative, a shower cap or towel can be worn to keep treated hair away from the sunbed surfaces.
- This unit intended for individual use. Only one pair of eyewear is included.

**⚠ DANGER**

**Some medication may increase your sensitivity to ultraviolet light. It is recommended that you consult a physician before using this sunbed if taking any medication or if you suspect that your skin might be especially sensitive to sunlight.**

**⚠ DANGER**

**Shock hazard.  
Do not operate this device near water or while you are wet.**

## Exposure Times

Follow the guidelines for skin type and exposure times as shown in the table below. Untanned persons should not tan on consecutive days during their first week of tanning. Never tan more than once a day. Tanning normally appears after the first few sessions and maximizes after approximately four weeks. Tan once or twice per week thereafter to maintain appearance. Persons already having a base tan may begin at advanced levels corresponding to the extent of their base tan.

RECOMMENDED EXPOSURE TIMES IN MINUTES		MAXIMUM EXPOSURE TIME IS 12 MINUTES				
Skin Type:	Level 1/Week 1 1st-3rd Sessions	Level 2	Level 3	Level 4	Subsequent Maximum	
I Sensitive Skin (Burns easily and severely and does not tan.)	NOT RECOMMENDED FOR TANNING					
II Light (Burns easily and severely and tans minimally.)	2	4	7	10	12	
III Normal (Burns moderately and tans average.)	3	6	9	12	12	
IV Dark (Burns minimally, tans easily and above average.)	4	7	10	12	12	



## Using Your Sunbed

When connected to the T-Max® Manager or T-Max® 1A or 3A.



A



B



C



D



E

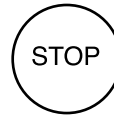

F



G

- A Face tanner control** - Turns face tanners on and off during use. Face tanner lamps require one minute to relight.
- B Shoulder tanner control** - Turns shoulder lamps on and off during use.
- C Body fan control** - Controls the speed of the body fan during use. (At your feet)
- D Body fan speed indicator** - Indicates speed of fan. (OFF - LOW - MED - HIGH)
- E Timer display** - Displays remaining time.
- F Stop button** - Interrupts tanning session.
- G Timer button** - Turns bed on. Timer display shows remaining time.

1. Lift canopy, lie down on bench (face up), lower canopy toward your body using canopy handle. Maintain at least 3" between your body and the canopy and rear lamp module acrylics.
2. Put on your safety goggles.
3. Assuming the remote system has been set to allow a pre-tanning delay time, the timer display (E) will repeatedly flash the delay symbol "dL" and then the remaining delay time. Press the timer button (G) or wait until the delay time has expired to begin the tanning session. The lamps will turn on and the timer will begin to count down.
4. When the timer reaches 0 the lamps turn off. If you want to interrupt your session before time expires, press the stop button (F).
5. Raise the canopy by using the canopy handle, do not push up on the acrylic shield. The cooling fans run for a period of time after the lamps shut off to aid in cooling the sunbed. The timer will indicate ".." as a reminder to clean the sunbed. After the sunbed is cleaned press the timer button and the display will return to "0".

### WARNING

**Wear protective eyewear.**  
**Failure to may result in severe burns or longterm injury to the eyes.**

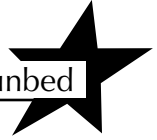

## Using Your Sunbed

When used as a stand alone unit or when connected to a remote system using a control relay.



A



B



C



D



E

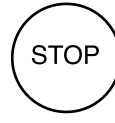

F

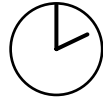

G

- A Face tanner control** - Turns face tanners on and off during use. Face tanner lamps require one minute to relight.
  - B Shoulder tanner control** - Turns shoulder lamps on and off during use.
  - C Body fan control** - Controls the speed of the body fan during use. (At your feet)
  - D Body fan speed indicator** - Indicates speed of fan. (OFF - LOW - MED - HIGH)
  - E Timer display** - Displays remaining time.
  - F Stop button** - Stops tanning session.
  - G Timer button** - Turns bed on. Timer display shows remaining time. If a lesser time is desired, press timer button until desired time is displayed.
1. Lift canopy, lie down on the bench (face up), lower the canopy toward your body using the canopy handle. Maintain at least 3" between your body and the canopy and rear lamp module acrylics.
  2. Put on your safety goggles.
  3. Press the timer button (G) to begin the tanning session. The lamps will turn on and the timer will begin to count down.
  4. If a tanning time less than the displayed time is desired, repeatedly press the timer button (G) to decrease the remaining time.
  5. When the timer reaches 0 the lamps turn off. If you want to stop your session before time expires, press the stop button (F). You will have ten seconds to restart with the remaining time, otherwise the timer will reset to 0.
  6. Raise the canopy by using the canopy handle, do not push up on the acrylic shield. The cooling fans run for a period of time after the lamps shut off to aid in cooling the sunbed.

### WARNING

**Wear protective eyewear.**  
**Failure to may result in severe burns or longterm injury to the eyes.**



# Care and Maintenance

---

## Cleaning After Use

Clean and disinfect your tanning bed's bench, canopy and rear lamp module after each use. Use a non-abrasive disinfectant cleaner that **does not contain ammonia or ammonia derivatives**. Ammonia may damage the acrylic shield. Spray the acrylic lightly with disinfectant and wipe dry with a clean soft cloth. We recommend Australian Gold® pH Neutral Disinfectant Cleaner.

## Thorough Periodic Cleaning

### Introduction

The cooling fans draw air through the bed and over time will cause a dust buildup on the lamps and reflectors. This will reduce the tanning effectiveness of the bed. When a dust buildup is observed, it is necessary to thoroughly clean the inside of the unit.

	<b>⚠ WARNING</b>
	<b>Shock hazard. Disconnect power before removing any protective covers.</b>

### Cleaning the Canopy and Bench

- Step 1** Remove the acrylic shields and lamps as described in *Lamp and Acrylic Replacement*.
- Step 2** With a soft cloth, wipe the entire length of each lamp.

- Step 3** Clean both sides of the acrylic shields with a non-ammonia disinfectant cleaner.
- Step 4** Wipe the reflectors with a clean damp cloth.
- Step 5** Reinstall the lamps and acrylic shields.
- Step 6** Clean or replace air filters on top of ballast tray and under bench (see *Final Adjustments*). Replace with 10" x 24" x 1" furnace filters.

## Mechanical Inspection

Your tanning bed has been built for years of service. To ensure trouble-free operation throughout its life, inspect the unit's mechanical integrity every 400-500 hours of use.

- Inspect the unit's fasteners verifying that all are firmly in place.
- Inspect lift adjustment. Adjust for proper lift if needed. See *Final Adjustments*.
- Inspect the AC power cord and its connections.
- Inspect the acrylic. Broken, cracked or badly scratched acrylics should be immediately replaced.
- Check damper operation. The damper limits the canopy's movement speed. Replace if canopy raises and lowers too quickly.



## Lamp and Acrylic Replacement

### *Introduction*

To be assured of maximum tanning effectiveness, change 100W lamps after approximately 800-1000 hours of use. Change 160W lamps after 600-800 hours of use. Tanning will continue after this time but at a slower rate.

This unit is equipped with electronic lamp starters. They last longer than traditional “glow tube” starters, light the lamps quicker, and reduce blackening on the ends of the lamps. It is no longer necessary to change lamp starters when changing lamps. As long as they function normally, meaning its lamp fires quickly and consistently, there is no need to change starters.

### *Maintenance Height Feature*

The **STARPOWER® 548** offers a convenience feature when maintenance must be performed. Behind the front access panel is a release handle (see *Final Adjustments*). With the canopy open, pull this handle and raise the canopy to its maintenance position, allowing easier access to lamps, etc. When finished, simply close the canopy to return to normal operation.

	<b>⚠ WARNING</b>
	<p><b>Shock hazard.</b>  <b>Disconnect power before removing any protective covers.</b></p>

### *Opening/Replacing Acrylic Shields*

Refer to the illustration on the next page while reading this instruction. The acrylic shield in the bench is secured in place by two quarter-turn latches along the front aluminum frame of the acrylic. The aluminum frame around the acrylic offers support as well as allowing the acrylic to hinge open without removing it from the bed. Use a coin or flat-bladed screwdriver to turn the latches a quarter turn to open the acrylic. Standing in front of the bed, lift the long edge of the acrylic. On the inside of the bench, along the front, are two supports for the bench acrylic. Release them from their clips and swing up to hold the acrylic open. You may remove the acrylic by lifting it out of its hinge channel along the back edge.

The other acrylics are held in place by four quarter-turn latches each. The canopy and rear lamp module acrylics also swing open on a hinge and may be removed by lifting out of the channel along the back edge.

When you are finished, simply reverse the above directions to secure the acrylic shields.

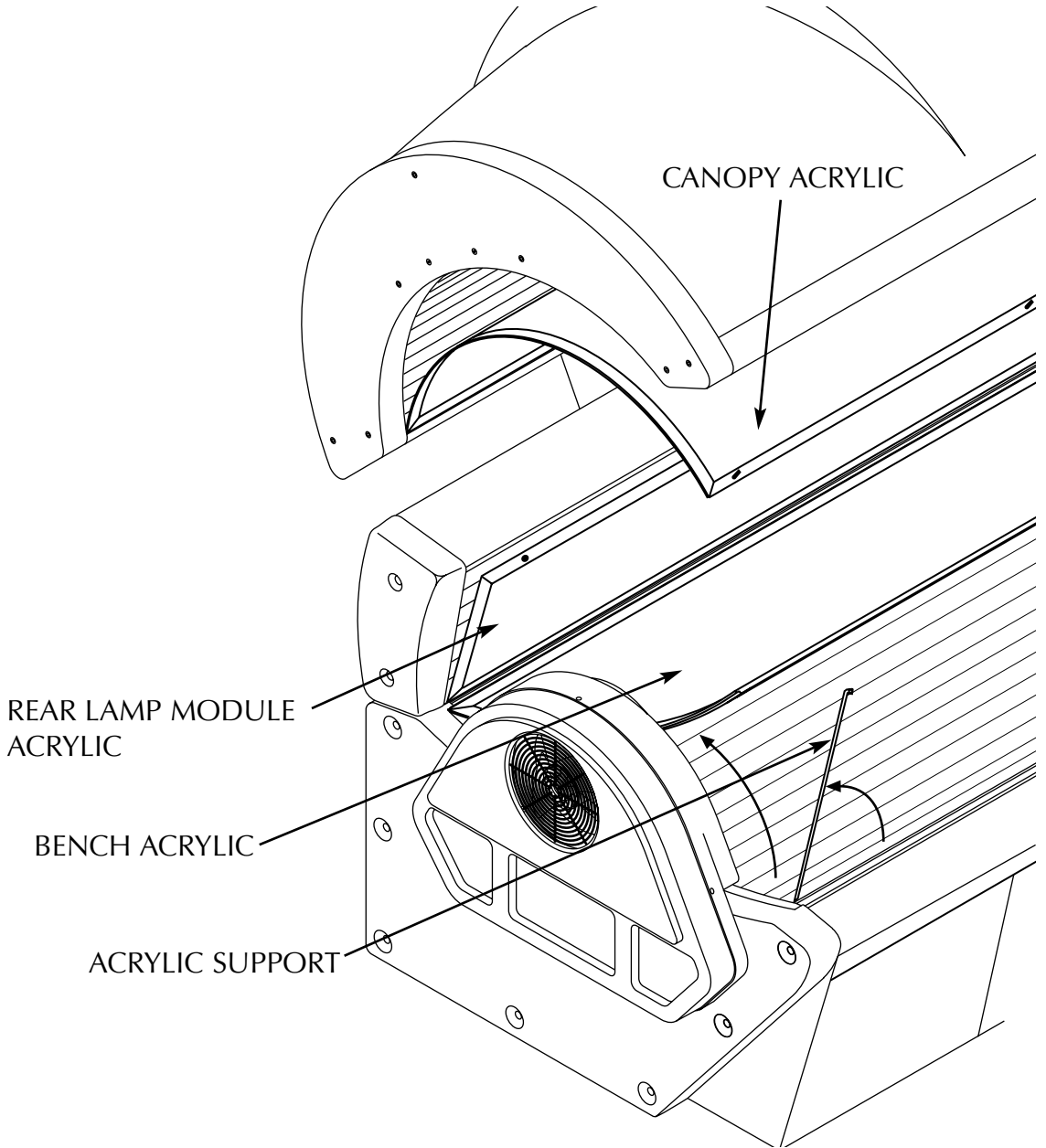



### ***Removing/Replacing Lamps***

After opening (or removing) the acrylic shields, replace lamps as follows.

- Step 1 Grasp a lamp at one end and at the middle and turn the lamp one quarter turn. Gently remove the lamp from its holders.
  
- Step 2 Reinstall the lamp by inserting the pins located on the ends of the lamp into the slots on top of the lamp holders and turn the lamp a quarter turn. It should click in place.

### ***Recommended Replacement Lamps***

We recommend using the lamps specified below. Use of uncertified lamps is a violation of Federal regulations and will void your warranty. The 100W lamps have an average life of 800-1000 hours of effective tanning use. The 160W lamps have an average life of 600-800 hours. Lamps used longer than that begin to lose their effectiveness even though they continue to light.

### ***Recommended Replacement Acrylics***

Acrylics vary greatly over time in their ability to effectively transmit UV light. Acrylics sold by ETS have been life tested to ensure proper transmission throughout their useful life.

## **ONLY THE FOLLOWING LAMPS HAVE BEEN CERTIFIED FOR USE IN THIS EQUIPMENT:**

Bench lamps

**BRONZING SUN™ PLUS Wolff® Model BSP 71-T12-100WR BI-PIN -or-  
SPEED® 225R Wolff® Model SPD71-T12-225R Bi-Pin**

Canopy and rear lamp module lamps

**Velocity® VS-R™ Wolff® Model VEL71-T12-160W VS-R Bi-Pin -or-  
SPEED® 315VS-R Wolff® Model SPD75-T12-315VS-R VS-R Bi-Pin**

SolarMax™ IFT facial unit

**Heraeus E400 HPT -or- Philips Model HPA 400/30s -or- CosmoTech Model 23045**

Shoulder tanner

**COSMOLUX® RA plus 15504/40W**



### **Removing/Replacing Face Tanner Lamps**

After removing the canopy and/or rear lamp module acrylic shields, replace the face tanner lamps as follows:

**Step 1** Support the face tanner assembly with your hand while unscrewing the two retaining screws. The face tanner glass casing will swing downward.

**Step 2** The lamp can now be exchanged. The lamp holders are equipped with spring contacts which enable the lamp to be removed easily. Remove the old lamp and discard. Install the new lamp, using a clean cloth or paper towel. Ensure that the lamp is firmly seated in the lamp holders.

**Note!** Never take hold of the lamp such that your fingers are in contact with the lamp glass. Finger oils will greatly reduce the lamp's operational life.

**Step 3** Gently close the face tanner glass casing and lock it closed with the screws. Ensure that the screws firmly secure the glass casing.

**⚠ DANGER**

**Unfiltered light from face tanner can cause severe burns. Never turn sunbed on while face tanner is disassembled or when glass filters are removed. Immediately discontinue use of this equipment if face tanner glass is broken or any unfiltered light can be seen escaping face tanner assembly.**

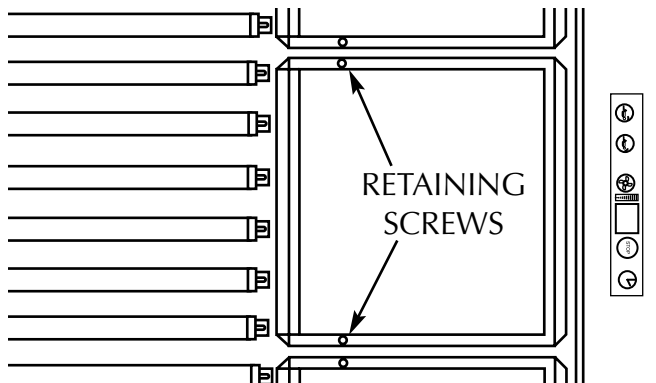



# Troubleshooting

---

<b>Problem</b>	<b>Solution</b>
Sunbed not tanning	<ol style="list-style-type: none"> <li>1. Clean sunbed, see <i>Thorough Periodic Cleaning</i>.</li> <li>2. Ensure supply voltage is between 208 and 230V AC.</li> <li>3. Replace lamps if lamp hours are greater than 800hrs.</li> <li>4. Replace acrylic.</li> </ol>
Lamps fail to light and timer display is blank	<ol style="list-style-type: none"> <li>1. Make sure the unit is connected to a power source.</li> <li>2. Check source of AC power. Reset circuit breaker or replace fuse.</li> </ol>
The last minute of tanning time does not count down from 59 seconds, but some time less than 59 seconds	If the timer button has been pressed to decrease tanning time during the session, the time expired in the current minute is subtracted from the last minute.
One or more lamps fail to light	<ol style="list-style-type: none"> <li>1. Check that lamp is installed correctly.</li> <li>2. Switch unlit lamp with a lamp that lights, if new lamp lights and old lamp still does not, replace old lamp.</li> </ol>
The face tanners will not come on	<ol style="list-style-type: none"> <li>1. Face tanner operation is initially delayed by 5 seconds.</li> <li>2. Face tanners will not relight until cooled.</li> <li>3. Replace face tanner lamp, see <i>Removing/Replacing Face Tanner Lamps</i>.</li> </ol>
The canopy will not stay up / The canopy will not stay down	Your sunbed uses a smooth gliding spring lift system to raise the canopy. This lift system may need to be adjusted slightly from time to time. See <i>Final Adjustments</i> for proper adjustment procedures. The canopy should raise easily as well as rest fully closed.
My canopy opens and closes too fast (slamming, not enough resistance)	Your sunbed utilizes a damper which limits the canopy's movement speed. This also serves as a safety device in case of spring lift failure as the canopy will not crash down. Replace the damper on back of unit.
I forgot what address, or "id", I set my sunbed to	By holding the body fan button for 3 seconds the timer display will briefly display three numbers; the installed timer software version, a factory set timer code and then the sunbed's "id" number.



<b>Problem</b>	<b>Solution</b>
Timer display is indicating Er 91	Timer software error. Disconnect and reapply power to the unit.
Timer display is indicating Er 92	Current sensor indicating unit is off when it should be on. Contact servicer.
Timer display is indicating Er 93	Current sensor indicating unit is on when it should be off. Contact servicer.
Timer display is indicating Er 94	Requested session time exceeds maximum time allowed.
Timer display changes to indicate a tanning time after the timer button is pressed but lamps do not come on	<ol style="list-style-type: none"> <li>1. Bypass plug is not installed, see <i>Remote Connections</i>.</li> <li>2. A non-SunStar® bypass has been used. See <i>Remote Connections</i>.</li> <li>3. If remote is being used, other than T-Max® Manager, the external timer may not be activated.</li> <li>4. Remote wiring is incorrect, see the instructions provided with the remote interface kit.</li> </ol>
My bed is connected to the T-Max® Manager remote system and when the delay time has expired the timer display starts counting down but the bed lights do not come on	The auto start feature of the remote system is disabled, see the instructions provided with your remote system.
My bed won't work with the T-Max® Manager remote system	<ol style="list-style-type: none"> <li>1. The sunbed must first be set to a unique address, see <i>Remote Connections</i>.</li> <li>2. The bypass or terminator plug may be installed in the series in an inappropriate location. Plug the bypass plug only into the bed at the end of the series.</li> </ol>
Timer display continues to show a 0 after the timer button is pressed	<ol style="list-style-type: none"> <li>1. T-Max® Manager remote system has not yet been set.</li> <li>2. Sunbed address is not set correctly, see <i>Remote Connections</i>.</li> </ol>



<b>Problem</b>	<b>Solution</b>
My bed is connected to a T-Max® remote system but I am having trouble getting into “id” mode	You have probably attempted to connect your sunbed to the remote system already. Disconnect the remote plug(s) from the ports at the front of the ballast tray, wait 90 seconds and try again.
My bed, connected to a T-Max® Manager, did not display “dL” but does indicate: “0”  a tanning time and the lamps have come on a tanning time but the lamps have not come on	<ol style="list-style-type: none"> <li>1. Remote device has not been set.</li> <li>2. The sunbed has not been connected to the remote system, see <i>Remote Connections</i>.</li> </ol> <ol style="list-style-type: none"> <li>1. Delay time of T-Max® Manager has not been set.</li> <li>2. Delay time has expired and session has begun. Auto start function of T-Max® Manager has been turned off. Press the timer button to turn on lamps.</li> </ol>
When auto-addressing the first bed does not register an “id”	When using the auto address feature of the T-Max® Manager you must wait 10 seconds from the time you start the auto address function before addressing the first bed.
When using a T-Max® 1A my sunbed won’t function properly	SunStar® Bypass plugs or terminator plugs may be needed if the T-Max® 1A and the sunbed are over 100 feet apart. Install the plugs in the open remote port in the sunbed and the T-Max® 1A.
My salon suffers frequent, short power outages and clients complain about losing session time	If you have a T-Max® Manager, changing parameter 23 from “0” to “1” will allow the tanning bed to remember how much time was left when power goes out and resume its session after power is restored. Consult your T-Max® Manager manual for information on setting parameters.

S-548  
 (canopy cover removed  
 and electrical shields  
 cut back)

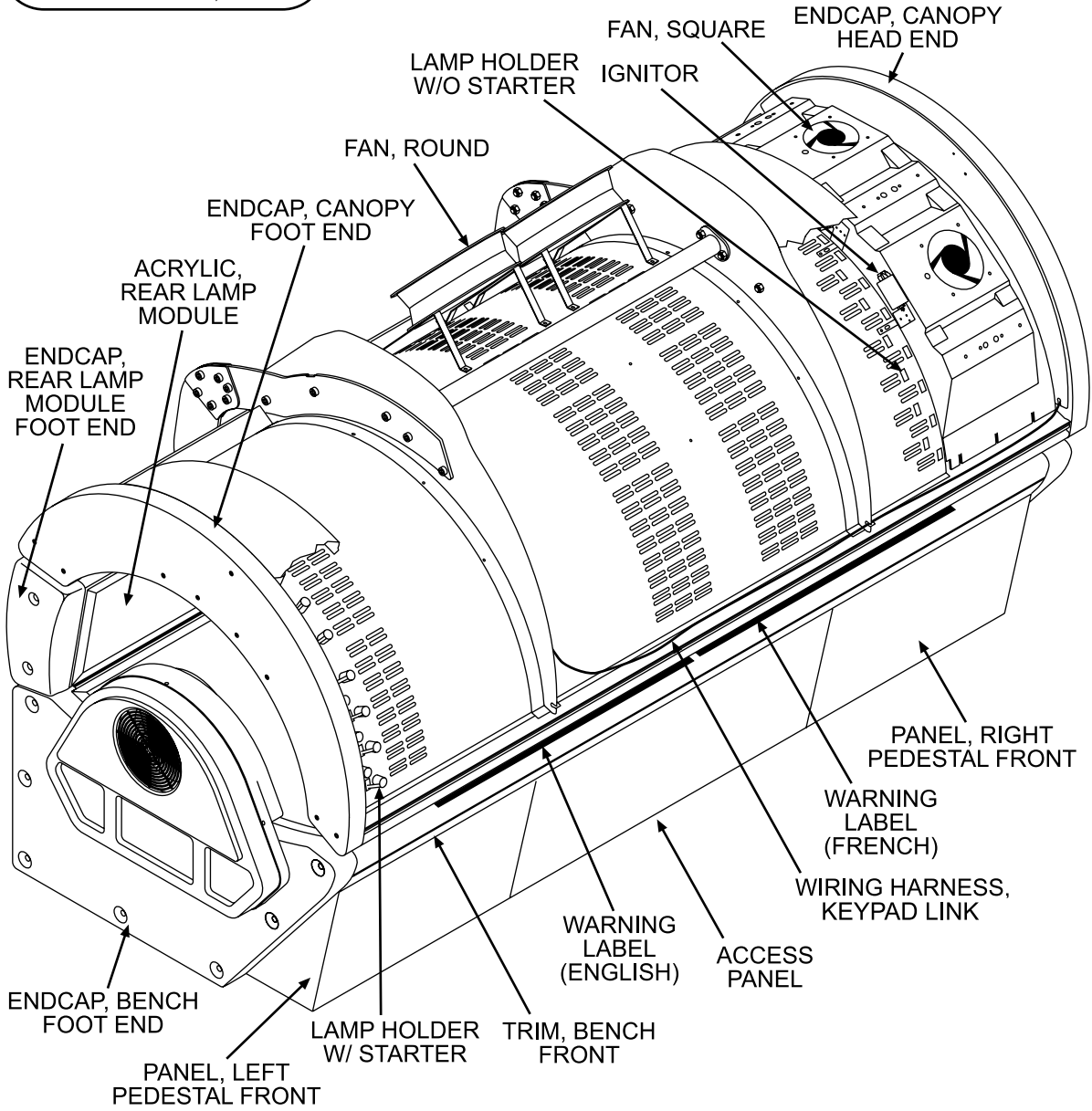

Shoulder Tanner  
(outside shroud  
removed)

ENDCAP, REAR LAMP  
MODULE HEAD END

SPEAKER

FAN, 6"

SHROUD,  
SHOULDER TANNER  
INSIDE

LAMP HOLDER,  
W/ STARTER  
(BEHIND COVER)

LAMP HOLDER,  
W/O STARTER  
(BEHIND COVER)

BALLAST, 80W

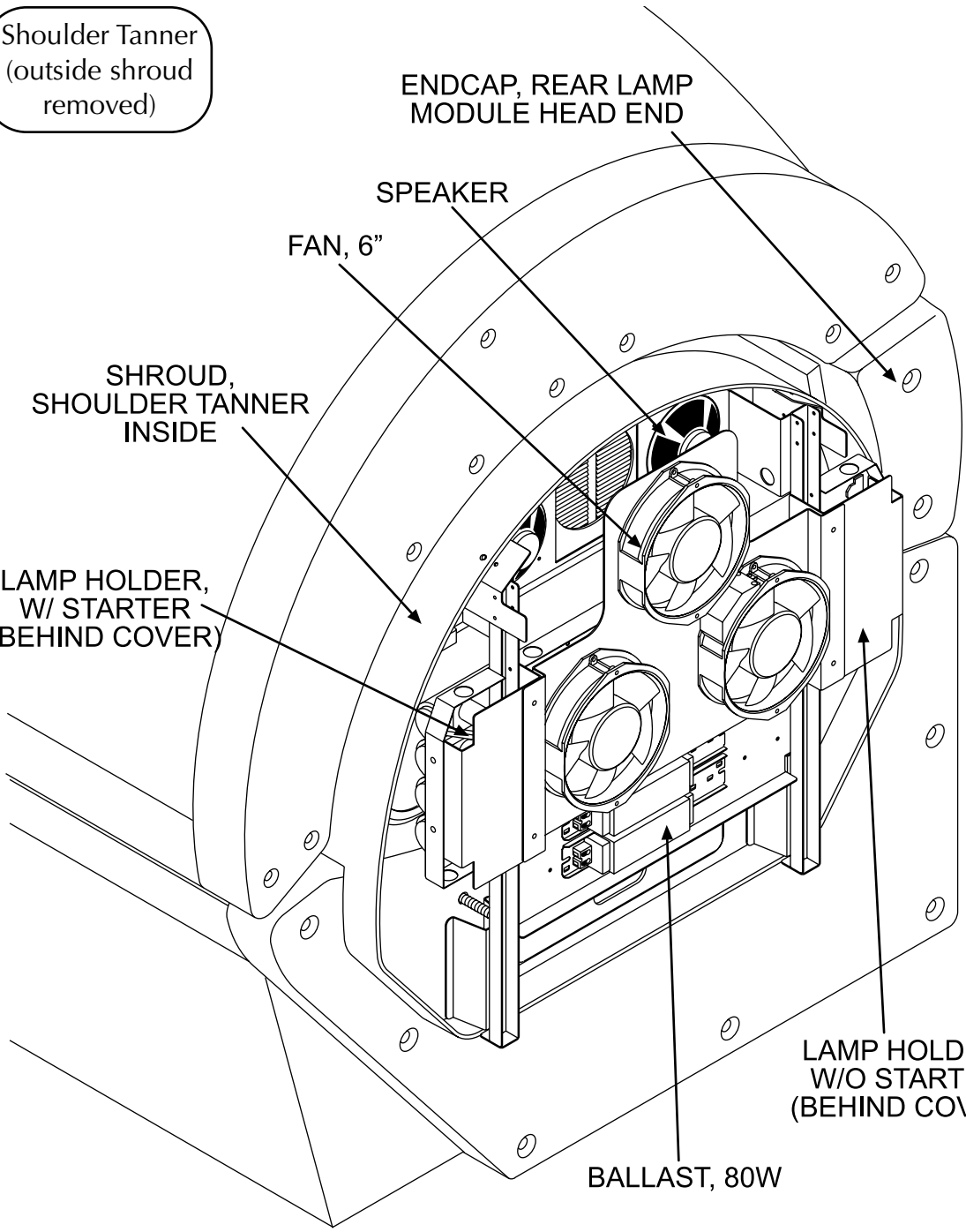

Body Fan

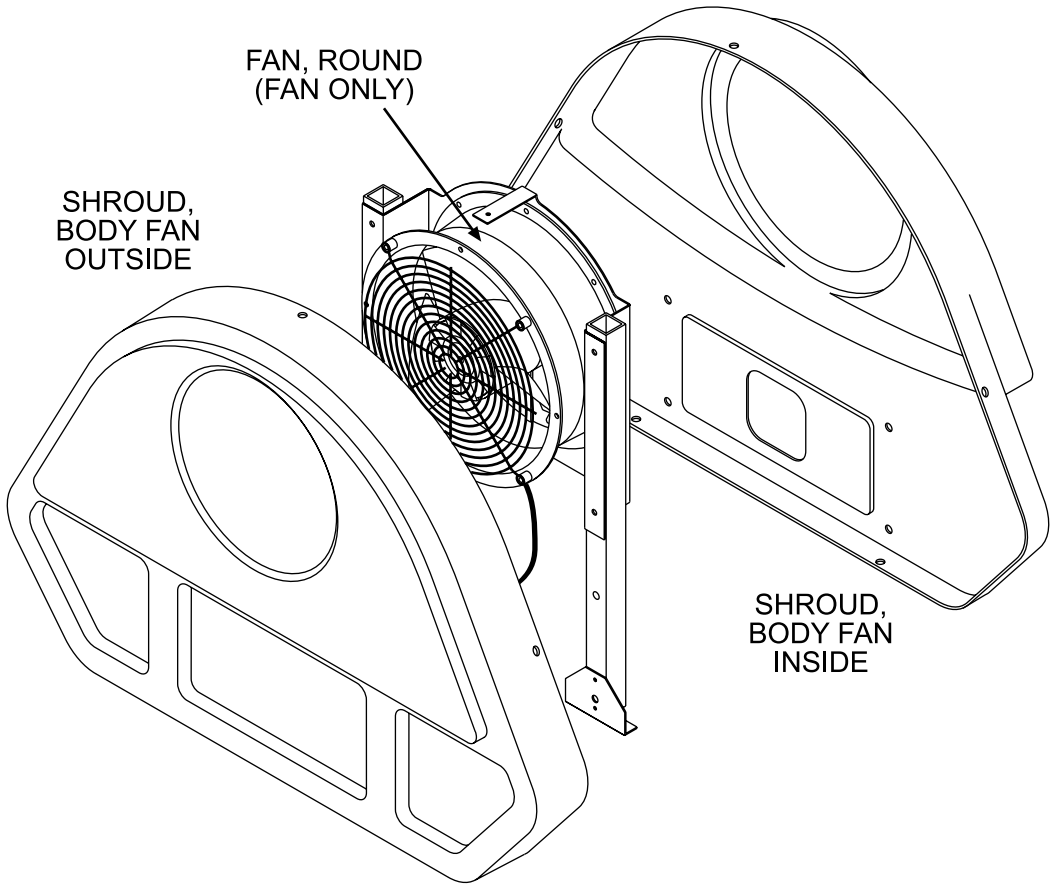

# Ballast Tray

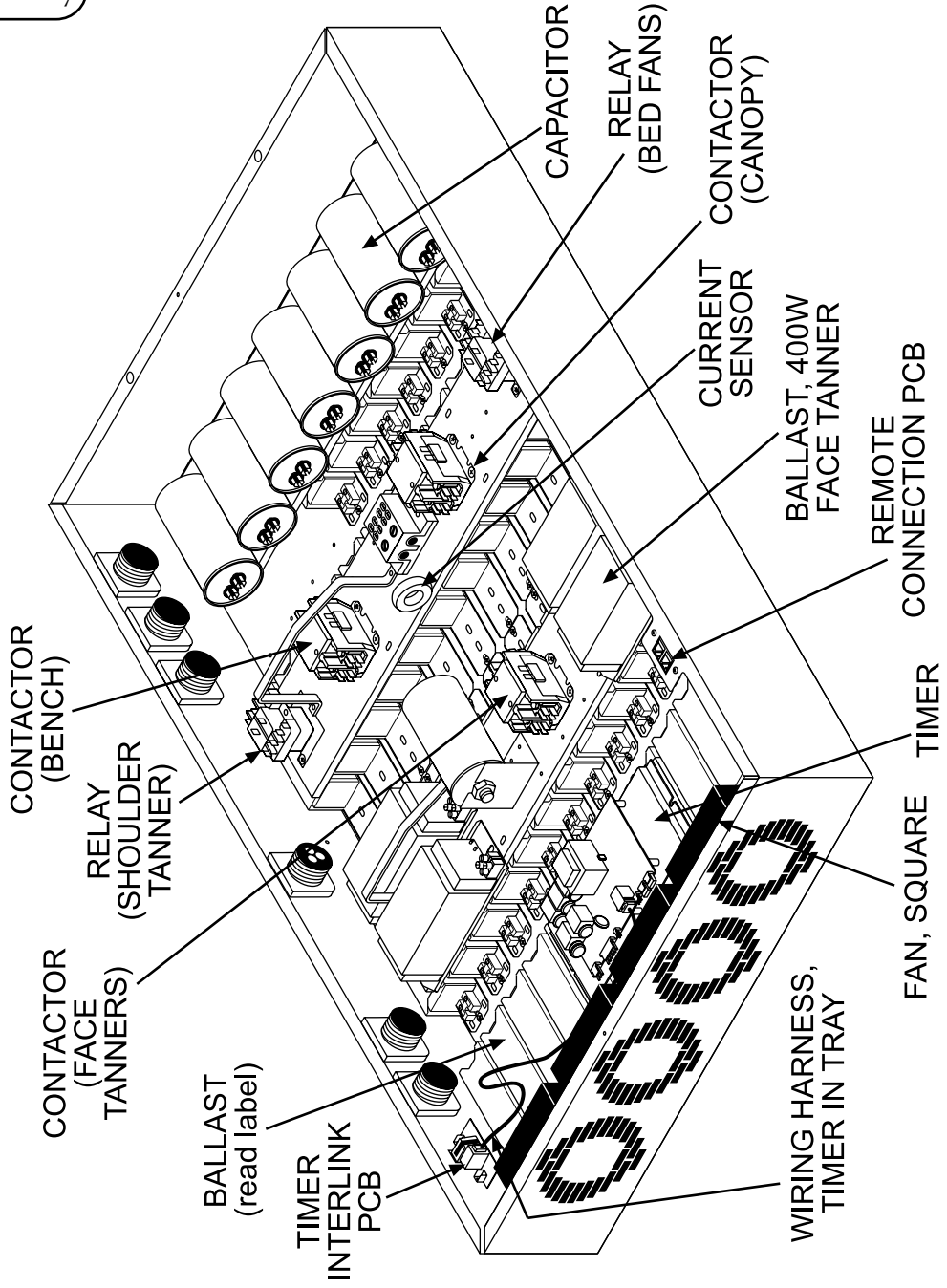

# Parts List

This is a list of parts which may be replaced by the consumer. When calling for parts, first state your bed model as S-548. Then refer to this list and preceding illustrations for proper identification.

Access Panel

Access Panel Key\*

Acrylic, Bench\* (with aluminum frame)

Acrylic, Canopy\* (with aluminum frame)

Acrylic, Rear Lamp Module

Acrylic, Shoulder Tanner\*

Ballast, 100W (bench lamps)

Ballast, 160W (canopy lamps)

Ballast, 80W (shoulder tanner lamps)

Ballast, 400W (face tanner lamps)

Body Fan (complete kit)

Capacitor, 75uF

Contactors

Cover, Canopy\*

Current Sensor

Damper\*

Endcap, Bench Foot End

Endcap, Bench Head End\*

Endcap, Canopy Foot End

Endcap, Canopy Head End

Endcap, Rear Lamp Module Foot End

Endcap, Rear Lamp Module Head End

Fan, 6"

Fan, Round

Fan, Square

Filter\*

Handle Kit\*

Hardware Kit, Assembly\*

Hardware Kit, Canopy\*

Hour Counter\*

Ignitor

Lamp Holder w/ Starter

Lamp Holder w/o Starter

Lamp Holder, Face Tanner\*

Lamps\*

Panel, Left Pedestal Front

Panel, Right Pedestal Front

Pillow\*

Relay

Remote Connection PCB

Remote Control Bypass Plug\*

Schematic Packet\*

Shoulder Tanner (complete kit)

Shroud, Body Fan Inside

Shroud, Body Fan Outside

Shroud, Shoulder Tanner Inside

Shroud, Shoulder Tanner Outside\*

Speakers (pair)

Starter, Electronic "Blue Juice"\*

Starter, S-2\* (shoulder lamps)

Support, Bench Acrylic\* ("kickstand")

Thermostat\* (for face tanner)

Timer

Timer Interlink PCB

Timer Keypad Kit\* (circuit board)

Timer Keypad Pushbuttons\*

Trim, Bench Front

Trim, Canopy Front\*

Warning Label (English)

Warning Label (French)

Wiring Harness, Keypad Link

Wiring Harness, Remote PCB to Timer\*

Wiring Harness, Resistor Code\*

Wiring Harness, Timer in Tray

Wiring Harness, RJ-11 Canopy to Bench\*

\* Not shown

What to do	WHEN			
	After each use	Monthly	400-500hrs	600-800hrs
A. Clean/Disinfect Interior Surfaces*	X			
B. Clean Lamps*		X		
C. Clean Reflectors*		X		
D. Clean Exterior		X		
E. Check/Clean Fans†		X		
F. Change Lamps**				X
H. Check Fasteners (nuts, bolts, etc.)*			X	
I. Check Power Cords*			X	
J. Change Filters***			X	

\* See *Care and Maintenance*

\*\* See *Lamp and Acrylic Replacement*

\*\*\* See *Final Adjustments*

† Fans are located on top of the canopy, under the bench, in the shoulder tanner and body fan, and at the side of the ballast drawer. Use a vacuum to clean.

MAINTENANCE LOG					
What	When	What	When	What	When
example B C D E	4/15/04				

Record this information for ease of service:  
Date of purchase: \_\_\_\_\_  
Serial number: \_\_\_\_\_

# STARPOWER 548

## Size

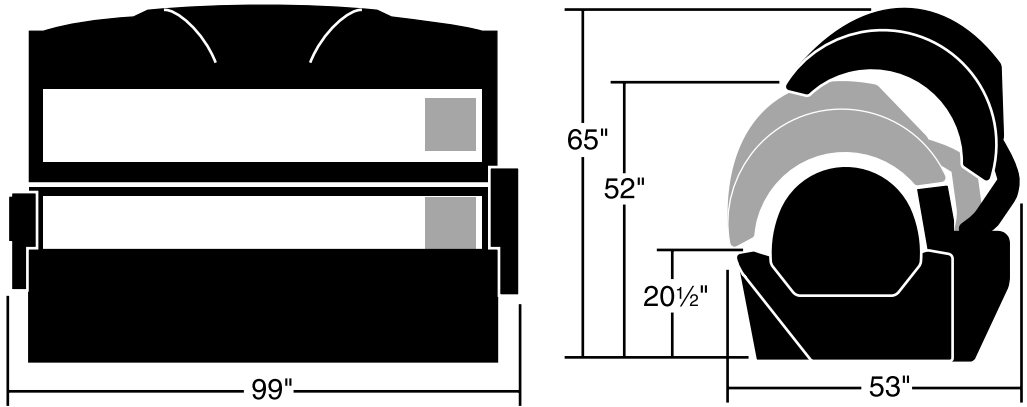

<b>Weight (Pounds)</b>	1050
<b>Recommended Room Size</b>	10'D x 10'W
<b>Electrical -</b>	
Voltage (AC)	220
Amperage	46
Circuit Breaker (Amps)	60
Outlet	Hardwire
<b>Main Lamps (see page iii)</b>	BRONZING SUN™ PLUS / Velocity® VS-R™
<b>Ballasts</b>	100W (bench) / 160W (canopy)
<b>Face Tanner</b>	SolarMax™ IFT
<b>FT Ballasts</b>	400W
<b>Cooling System</b>	825cfm body fan at foot end / 220cfm fan at head end
<b>Timer System</b>	Digital
<b>Max. Exposure Time</b>	12minutes
<b>Back-up Timer</b>	Digital "watchdog" circuitry
<b>Remote Capability</b>	T-Max® compatible



Proudly manufactured  
in the U.S.A.

U.S. Patent 6,660,025 B2

